

## RIDUTTORI EPICICLOIDALI DI PRECISIONE

Giochi angolari ridotti fino a 4'

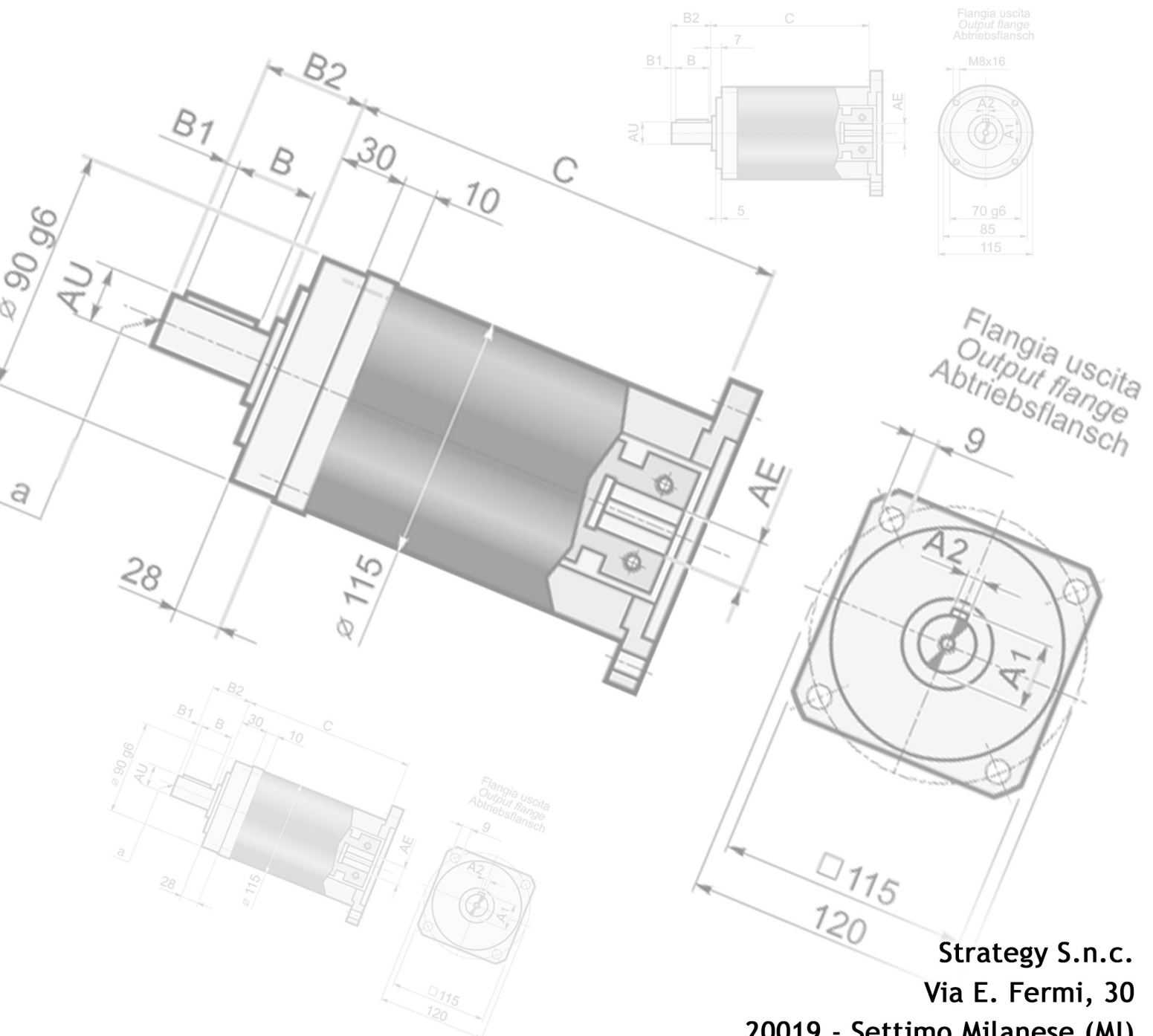

Strategy S.n.c.  
 Via E. Fermi, 30  
 20019 - Settimo Milanese (MI)  
 Tel. 02.33.51.25.49 r.a. Fax 02.33.51.24.89  
 e-mail: info@strategysnc.com

## RIDUTTORI EPICICLOIDALI DI PRECISIONE

---

INDICE	<i>INDEX</i>	INHALTSVERZEICHNIS	
1.0	Caratteristiche	<i>Characteristics</i>	Merkmale 2
1.1	Designazione	<i>Designation</i>	Bezeichnung 3
1.2	Simbologia	<i>Symbols</i>	Verwendete symbole 3
1.3	Selezione	<i>Selection</i>	Getriebeauswahl 4
1.4	Verifica termica	<i>Temperature check</i>	Temperaturprüfung 6
1.5	Gioco angolare	<i>Backlash</i>	Winkelspiel 9
1.6	Carichi radiali e assiali su albero lento	<i>Radial and axial loads on output shaft</i>	Radial-und Axiallasten an der Ausgangswelle 9
1.7	Lubrificazione	<i>Lubrication</i>	Schmierung 9
1.8	Momento d'inerzia	<i>Moment of inertia</i>	Traegheitsmoment 10
1.9	Dati tecnici	<i>Technical data</i>	Technische Daten 12-18
1.10	Dimensioni	<i>Dimensions</i>	Abmessungen 12-19
1.11	Istruzioni per il montaggio del motore	<i>Instructions for assembly of motor</i>	Anleitung für Motormontage 20-21
1.12	Esempi di applicazioni	<i>Examples of applications</i>	Anwendungsbeispiele 22-23
1.13	Formulario	<i>Formulary</i>	Formelsammlung 24

## RIDUTTORI EPICICLOIDALI DI PRECISIONE

### 1.0 CARATTERISTICHE

La serie di riduttori epicicloidali REP è il risultato di un ottimo rapporto tra economicità del prezzo e garanzia di precisione delle caratteristiche di funzionamento.

I nostri riduttori sono stati realizzati per un utilizzo prevalente sulle seguenti applicazioni:

- Macchine utensili
- Macchine per la lavorazione del legno
- Linee transfer
- Macchine da stampa
- Macchine automatiche per confezionamento ed imballaggio
- Automazioni
- Manipolatori
- Macchine serigrafiche
- Guide lineari

La gamma dei riduttori REP è costituita da 4 grandezze (075, 100, 125 e 150), a 1, 2 e 3 stadi di riduzione, ognuna con due o tre tipi di alberi uscita (AU...) e flange uscita di tipo FLT e FLQ.

**Corpo:** costruito in acciaio speciale da nitrurazione, garantisce robustezza e una elevata affidabilità nel tempo.

**Flange:** le flange in entrata ed in uscita sono costruite in alluminio e sono disponibili in molteplici varianti costruttive.

**Alberi:** sono costruiti in acciaio legato bonificato.

**Ingranaggi:** in acciaio legato da cementazione e tempra, con dentature rettificata.

**Cuscinetti:** di elevata qualità opportunamente dimensionati per garantire elevate durate e silenziosità di funzionamento.

### 1.0 CHARACTERISTICS

*The planetary gearbox REP series is the result of the outstanding combination competitive price / precision guaranteed with regard to operating features.*

*Our gearboxes are manufactured for prevailing utilization in the following applications:*

- *Machine tools*
- *Machines for woodworking*
- *Transfer machines*
- *Printing machines*
- *Automatic machines for packaging*
- *Automation*
- *Mechanical hands*
- *Silk-screen process machines*
- *Linear guides*

*The REP series is available in 4 sizes (075, 100, 125 and 150), with 1, 2 or 3 reduction stages, with two or three types of output shaft (AU...) and two types of output flange (FLT and FLQ).*

**Housing:** *made of special nitrided steel to assure strength, high reliability and long life.*

**Flanges:** *input and output flanges made of aluminium and available in several versions.*

**Shafts:** *made of hardened and tempered alloy steel.*

**Gears:** *made of casehardened and tempered alloy steel, with ground toothing.*

**Bearings:** *high quality and suitably sized to assure long life and noiseless working.*

### 1.0 MERKMALE

Die REP Serie von Planetengetrieben ist das Ergebnis des hervorragenden Beziehung guter Preis / garantierte Präzision der Betriebseigenschaften. Unsere Getriebe sind für überwiegende Verwendung in der folgenden Applikationen hergestellt:

- Werkzeugmaschinen
- Holzbearbeitungsmaschinen
- Transfermaschinen
- Druckmaschinen
- Automatische Verpackungsmaschinen
- Automation
- Manipulatoren
- Siebdruckmaschinen
- Linearführungen

Die REP Serie ist in 4 Größen (075, 100, 125 und 150) mit 1, 2 oder 3 Untersetzungsstufen, mit zwei oder drei Typen von Abtriebswellen (AU...) und zwei Typen von Abtriebsflanschen (FLT und FLQ) verfügbar.

**Gehäuse:** aus Spezial-Nitrierstahl. Garantiert Robustheit und dauerhaft hohe Zuverlässigkeit.

**Ein- u. Ausgangsflansche:** aus Aluminium, in zahlreichen Varianten lieferbar.

**Wellen:** aus vergütetem Legierungsstahl.

**Zahnräder:** aus geärteten Einsatzstahl mit geschliffenen Zahnflanken.

**Lager:** sind hochwertig und zweckmäßig bemessen, um eine lange Lebensdauer und einen geräuscharmen Lauf zu garantieren.

## RIDUTTORI EPICICLOIDALI DI PRECISIONE

### 1.1 DESIGNAZIONE

### 1.1 DESIGNATION

### 1.1 BEZEICHNUNG

Riduttore epicicloidale Planetary gearbox Planetengetriebe	Grandezza Size Größe	Numero di stadi Steps Untersetzungsstufen	Coassiale Coaxial/ Koaxial	Rapporto di riduzione Ratio Untersetzungsverhältnis	Albero uscita Output shaft Durchmesser Abtriebswelle	Flangia uscita Output flange Ausgangsflansch	Albero entrata Input shaft Durchmesser Eingangswelle	Flangia in entrata Input flange Eingangsflansch	Classe di precisione Precision class Präzisionsklasse
<b>REP</b>	<b>075</b>	<b>2</b>	<b>C</b>	<b>100</b>	<b>AU16</b>	<b>FLT</b>	<b>AE12</b>	<b>P03</b>	<b>P</b>
	<b>075</b> <b>100</b> <b>125</b> <b>150</b>	<b>1</b> <b>2</b> <b>3</b>	<b>C</b>	<b>3 - 343</b>	Vedi tabelle See tables Siehe Tab.	<b>FLT</b> <b>FLQ</b>	Vedi tabelle See tables Siehe Tab.	Vedi tabelle See tables Siehe Tab.	

### 1.2 SIMBOLOGIA

### 1.2 SYMBOLS

### 1.2 VERWENDETE SYMBOLE

$n_{max}$	[arcmin]	Gioco angolare standard	<i>Standard backlash</i>	Standard Winkelspiel
<b>C</b>	—	Coefficiente di dispersione termica	<i>Loss of heat coefficient</i>	Wärmeverlustkoeffizient
<b>F<sub>A2</sub></b>	[N]	Carico assiale in uscita [N] a 300min <sup>-1</sup>	<i>Output axial load [N] at 300min<sup>-1</sup></i>	Axiallast an der Abtriebswelle bei 300min <sup>-1</sup>
<b>fc</b>	—	Fattore di ciclo	<i>Cycle factor</i>	Zyklusfaktor
<b>F<sub>R2</sub></b>	[N]	Carico radiale nominale in uscita [N] a 300min <sup>-1</sup>	<i>Rated output radial load [N] at 300min<sup>-1</sup></i>	Nenn-Radiallast an der Abtriebswelle bei 300min <sup>-1</sup>
<b>f<sub>v</sub></b>	—	Fattore di ventilazione	<i>Ventilation factor</i>	Lüftungsfaktor
<b>i</b>	—	Rapporto di riduzione nominale	<i>Nominal ratio</i>	Nenn-Untersetzungsverhältnis
<b>J</b>	[kg·cm <sup>2</sup> ]	Momento d'inerzia	<i>Moment of inertia</i>	Traegheitsmoment
<b>KU, KM</b>	—	Coefficiente di utilizzo	<i>Duty coefficient</i>	Anwendungskoeffizient
<b>L<sub>h</sub></b>	[h]	Durata cuscinetti	<i>Bearing life</i>	Lebensdauer der Lager
<b>LpA</b>	dB(A)	Livello di rumorosità dB(A) a 3000 min <sup>-1</sup>	<i>Noise level dB(A) at 3000 min<sup>-1</sup></i>	Geräuschpegel dB(A) bei 3000 min <sup>-1</sup>
<b>n<sub>1 max</sub></b>	[min <sup>-1</sup> ]	Velocità massima in entrata	<i>Maximum input speed</i>	Maximale Eingangsdrehzahl
<b>n<sub>1 nom</sub></b>	[min <sup>-1</sup> ]	Velocità nominale in entrata	<i>Nominal input speed</i>	Nenn-Eingangsdrehzahl
<b>n<sub>1E</sub></b>	[min <sup>-1</sup> ]	Velocità media in ingresso	<i>Average input speed</i>	Durchschnittsdrehzahl am Antrieb
<b>n<sub>2E</sub></b>	[min <sup>-1</sup> ]	Velocità di rotazione media in uscita	<i>Average rotation speed at output</i>	Durchschnittsdrehzahl am Abtrieb
<b>n<sub>2N</sub></b>	[min <sup>-1</sup> ]	Velocità di rotazione nominale in uscita	<i>Rated rotation speed at output</i>	Nennndrehzahl am Abtrieb
<b>P<sub>0</sub></b>	[W]	Potenza persa a vuoto	<i>Loadless friction power</i>	Verlustleistung ohne Last
<b>P</b>	[W]	Potenza persa proporzionale alla potenza applicata	<i>Friction power proportional to the applied</i>	Verlustleistung proportional zu der angewandten Leistung
<b>Rd</b>	—	Rendimento dinamico	<i>Dynamic efficiency</i>	Dynamischer Wirkungsgrad
<b>R<sub>t</sub></b>	[Nm / arcmin]	Rigidità torsionale	<i>Torsional rigidity</i>	Drehfestigkeit
<b>T<sub>0</sub></b>	[°C]	Temperatura ambiente	<i>Ambient temperature</i>	Umgebungstemperatur
<b>T<sub>max</sub></b>	[°C]	Temperatura massima ammessa di funzionamento	<i>Max. permitted temperature of operation</i>	Max. Zulässigen Betriebstemperatur
<b>T<sub>1AMOT</sub></b>	[Nm]	Massima coppia di accelerazione del motore	<i>Max. acceleration torque of motor</i>	Maximales Beschleunigungsdrehmoment des Motors
<b>T<sub>1E</sub></b>	[Nm]	Coppia media in entrata	<i>Average torque at input</i>	Durchschnittsdrehmoment am Antrieb
<b>T<sub>1n</sub></b>	[Nm]	Coppia nominale del motore	<i>Motor rated torque</i>	Nennndrehmoment des Motors
<b>T<sub>2A</sub></b>	[Nm]	Massima coppia di accelerazione in uscita	<i>Max. acceleration torque at output</i>	Maximales Beschleunigungsdrehmoment am Abtrieb
<b>T<sub>2E</sub></b>	[Nm]	Coppia media in uscita	<i>Average torque at output</i>	Durchschnittsdrehmoment am Abtrieb
<b>T<sub>2N</sub></b>	[Nm]	Coppia nominale intermittente in uscita	<i>Rated intermittent output torque</i>	Nenn-Abtriebsmoment (im Aussetzbetrieb)
<b>T<sub>2s</sub></b>	[Nm]	Coppia massima di emergenza in uscita	<i>Maximum emergency output torque</i>	Maximale Überlast
<b>c</b>	[s]	Costante di tempo	<i>Time constant</i>	Zeitkonstante
<b>T<sub>s</sub></b>	[°C]	Temperatura massima di equilibrio	<i>Maximum temperature of equilibrium</i>	Maximale Ausgeglichenen Temperatur
<b>Zh</b>	[1/h]	Numero di cicli ora	<i>Number or cycles per hour</i>	Zykluszahl pro Stunde

## RIDUTTORI EPICICLOIDALI DI PRECISIONE

### 1.3 SELEZIONE

#### Verifica meccanica

La selezione dei riduttori epicicloidali REP deve essere effettuata valutando se il servizio è intermittente o continuo.  
Noto il ciclo di lavoro:

### 1.3 SELECTION

#### Mechanical check

The selection of the REP planetary gearbox depends on whether the duty is continuous or intermittent.  
The working cycle being:

### 1.3 GETRIEBEAUSWAHL

#### Mechanische Prüfung

Bei der Wahl des REP Planetengetriebes soll es berücksichtigt werden, ob es um Aussetz- oder Dauerbetrieb handelt.  
Bei bekannten Arbeitszyklus:

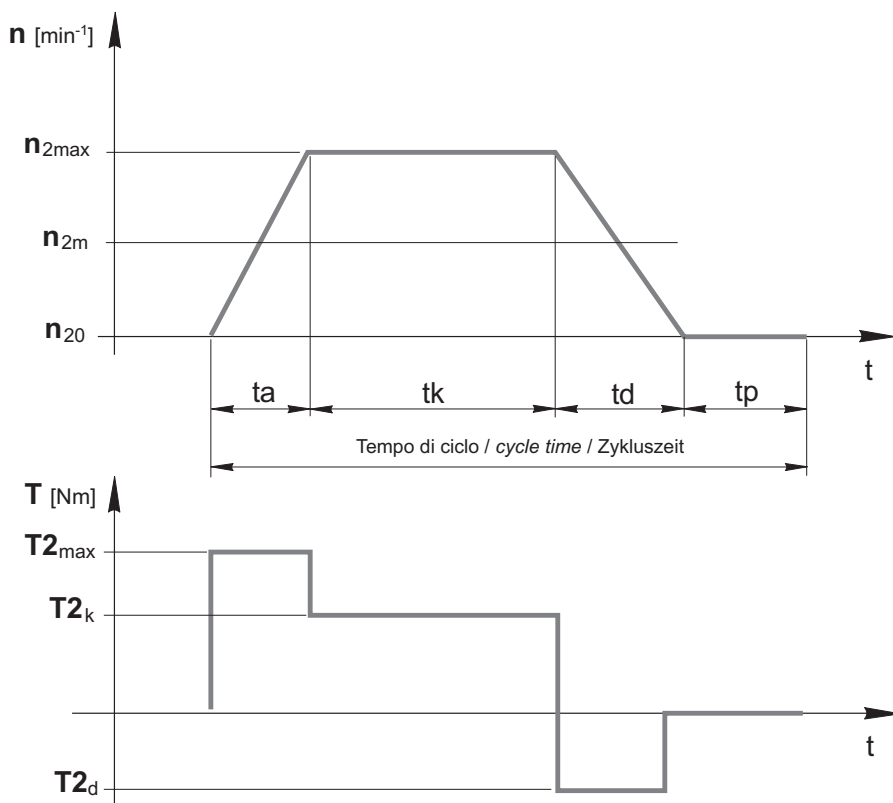

$n_{2max}$ [min <sup>-1</sup> ]	Velocità massima Max. speed Max. Drehzahl
$n_{2m}$ [min <sup>-1</sup> ]	Velocità media Average speed Durchschnittsdrehzahl
$n_{20}$ [min <sup>-1</sup> ]	Velocità zero (motore fermo) Zero speed (motor off) Null Drehzahl (stillstehender Motor)
$t_a$ [s]	Tempo di accelerazione Acceleration time Beschleunigungszeit
$t_k$ [s]	Tempo di funzionamento a regime Standard time of operation Standardbetriebszeit
$t_d$ [s]	Tempo di decelerazione Deceleration time Verzögerungszeit
$t_p$ [s]	Tempo di pausa Pause time Pausenzeit
$T_{2max}$ [Nm]	Coppia massima Max. torque Maximaldrehmoment
$T_{2k}$ [Nm]	Coppia a regime Standard torque Standardbetriebsdrehmoment
$T_{2d}$ [Nm]	Coppia in decelerazione Decelerating torque Verzögerungsdrehmoment

si definiscono i coefficienti di utilizzo KU, KM secondo le seguenti formule:

calculate KU, KM duty coefficients with the following formulae:

darf der Anwendungskoeffizient KU, KM wie folgt kalkuliert werden:

$$KU = \frac{t_a t_k t_d}{t_a t_k t_d t_p} \cdot 100 \text{ [%]}$$



se:  
if:  
ob: **KU < 60%**  
e / and / und  
**KM < 20 min**



**Funzionamento intermittente**  
**Intermittent duty**  
**Aussetzbetrieb**

e  
and  
und

$$KM = \frac{t_a t_k t_d}{60} \text{ [min]}$$



se:  
if:  
ob: **KU 60**  
o / or / oder  
**KM 20 min**



**Funzionamento continuo**  
**Continuous duty**  
**Dauerbetrieb**

## RIDUTTORI EPICICLOIDALI DI PRECISIONE

### Funzionamento intermittente

In questo caso, deve essere verificata la seguente relazione:

### Intermittent duty

In case of intermittent duty, the following equation should be checked:

$$T_{2A} T_{1AMOT} i f_c R_d$$

Dove :  
 $T_{2A}$  = massima coppia di accelerazione in uscita garantita dal riduttore [Nm] (vedi tabelle delle prestazioni)  
 $T_{1AMOT}$  = massima coppia di accelerazione del motore [Nm]  
 $i$  = rapporto di riduzione  
 $f_c$  = fattore di ciclo (vedi tabella 1)  
 $R_d$  = rendimento dinamico (vedi tabella delle prestazioni)

Where:  
 $T_{2A}$  = max. acceleration torque at output guaranteed by the gearbox [Nm] (see tables of performance)  
 $T_{1AMOT}$  = max. acceleration torque of motor [Nm]  
 $i$  = reduction ratio  
 $f_c$  = cycle factor (see table 1)  
 $R_d$  = dynamic efficiency (see table of performance)

Infine, si confronti il valore della velocità in entrata massima consentita ( $n_{1max}$ , v. tabella delle prestazioni) con la massima velocità di rotazione raggiunta in entrata dall'applicazione ( $n'_{1max}$ ). Deve essere:

Finally, the permitted max. input speed ( $n_{1max}$ , see table of performance) has to be compared with the max. rotation speed reached by the application at input ( $n'_{1max}$ ). The result has to be as follows:

$$n_{1max} > n'_{1max}$$

### Aussetzbetrieb

Bei Aussetzbetrieb soll die folgende Relation festgestellt werden:

Wobei:  
 $T_{2A}$  = maximales Beschleunigungsdrehmoment am Abtrieb, das von Getriebe garantiert wird [Nm] (siehe Leistungstabellen)  
 $T_{1AMOT}$  = maximales Beschleunigungsdrehmoment des Motors [Nm]  
 $i$  = Übersetzungsverhältnis  
 $f_c$  = Zyklusfaktor (siehe Tabelle 1)  
 $R_d$  = dynamischer Wirkungsgrad (siehe Leistungstabelle)

Schließlich sollen das zulässige Maximaldrehzahl am Antrieb ( $n_{1max}$ , siehe Leistungstabelle) und das in der Applikation erreichten Maximaldrehzahl am Antrieb verglichen werden ( $n'_{1max}$ ). Das Ergebnis soll wie folgt sein:

### Funzionamento continuo

In questo caso devono essere verificate le seguenti relazioni:

### Continuous duty

In case of continuous duty the following equations have to be checked:

- 1)  $T_{2A} T_{1AMOT} i f_c R_d$
- 2)  $T_{2N} T_{2E}$
- 3)  $n_{2N} n_{2E}$

### Dauerbetrieb

Bei Dauerbetrieb sind die folgenden Relationen zu prüfen:

Dove :  
 $T_{2A}$  = massima coppia di accelerazione in uscita garantita dal riduttore [Nm] (vedi tabelle delle prestazioni)  
 $T_{1AMOT}$  = massima coppia di accelerazione del motore [Nm]  
 $i$  = rapporto di riduzione  
 $f_c$  = fattore di ciclo (vedi tabella 1)  
 $R_d$  = rendimento dinamico (vedi tabella delle prestazioni)  
 $T_{2N}$  = coppia nominale intermittente in uscita ammessa dal riduttore [Nm] (vedi tabelle delle prestazioni)  
 $T_{2E}$  = coppia media in uscita [Nm], ricavabile dalla seguente relazione:

Where:  
 $T_{2A}$  = max. acceleration torque at output guaranteed by the gearbox [Nm] (see tables of performance)  
 $T_{1AMOT}$  = max. acceleration torque of motor [Nm]  
 $i$  = reduction ratio  
 $f_c$  = cycle factor (see table 1)  
 $R_d$  = dynamic efficiency (see table of performance)  
 $T_{2N}$  = rated intermittent allowable torque at output [Nm] (see tables of performance)  
 $T_{2E}$  = average torque at output [Nm], to be calculated with the following formula:

$$T_{2E} = \sqrt[3]{\frac{T_{2MAX}^3 n_{2m} t_a \dots T_{2n}^3 n_{2n} t_n}{t_a n_{2m} \dots t_n n_{2n}}}$$

Wobei:  
 $T_{2A}$  = maximales Beschleunigungsdrehmoment am Abtrieb, das von Getriebe garantiert wird [Nm] (siehe Leistungstabellen)  
 $T_{1AMOT}$  = maximales Beschleunigungsdrehmoment des Motors [Nm]  
 $i$  = Übersetzungsverhältnis  
 $f_c$  = Zyklusfaktor (siehe Tabelle 1)  
 $R_d$  = dynamischer Wirkungsgrad (siehe Leistungstabelle)  
 $T_{2N}$  = Zulässiges intermittierendes Nennmoment am Abtrieb [Nm] (siehe Leistungstabelle)  
 $T_{2E}$  = Durchschnittsdrehmoment am Abtrieb [Nm] wird mit der folgenden Formel

$T_{2n}, n_{2n}, t_n$  = valori riferiti allo step ennesimo.

$T_{2n}, n_{2n}, t_n$  = values referred to nth step.

$T_{2n}, n_{2n}, t_n$  = Werte mit Bezug auf n-te Stufe.

## RIDUTTORI EPICICLOIDALI DI PRECISIONE

$n_{2N}$  = velocità di rotazione nominale in uscita [ $\text{min}^{-1}$ ] (vedi tabelle delle prestazioni:  
 $n_{2N} = n_{1nom}/i$ )  
 $n_{2E}$  = velocità di rotazione media in uscita [ $\text{min}^{-1}$ ] e vale:

$n_{2N}$  = rated rotation speed at output [ $\text{min}^{-1}$ ]  
 (see tables of performance  $n_{2n} = n_{1nom}/i$ )  
 $n_{2E}$  = average rotation speed at output [ $\text{min}^{-1}$ ]

$n_{2N}$  = Nenndrehzahl am Abtrieb [ $\text{min}^{-1}$ ]  
 (siehe Leistungstabelle  $n_{2n} = n_{1nom}/i$ )  
 $n_{2E}$  = Durchschnittsdrehzahl am Abtrieb, wird wie folgt kalkuliert:

$$n_{2E} = \frac{n_{2m} \cdot t_a \dots n_{2n} \cdot t_n}{t_a \dots t_n} \quad [\text{min}^{-1}]$$

Se il riduttore viene utilizzato in funzionamento continuo, in condizioni di moto e carico uniforme, la scelta del riduttore può essere effettuata secondo la seguente relazione:

*In case of continuous duty, uniform load and uniform motion, the following formula can be used for selecting the type of gearbox:*

Im Falle von Dauerbetrieb, mit gleichmäßigen Last und Betrieb, darf die Wahl des Getriebes mit der folgenden Formel getroffen werden:

$$T_{2n} \frac{T_{1n} \cdot i \cdot R_d}{0.65}$$

Dove:  
 $T_{1n}$  [Nm] è la coppia nominale del motore.

Where:  
 $T_{1n}$  [Nm]= motor rated torque.

Wobei:  
 $T_{1n}$  [Nm] ist das Nenndrehmoment des Motors.

**Determinazione di  $f_c$**   
 Il valore del fattore di ciclo  $f_c$  dipende dal numero di cicli ora  $Z_h$ , dove:

**Calculation of  $f_c$**   
 The value of  $f_c$  cycle factor depends on the number of cycles per hour  $Z_h$ :

**Berechnung von  $f_c$**   
 Der Wert von  $f_c$  Zyklusfaktor hängt von der Zykluszahl pro Stunde  $Z_h$  ab:

$$Z_h \frac{3600}{t_a \cdot t_k \cdot t_d + t_p} \quad [1/h]$$

Una volta determinato  $Z_h$ , consultando la seguente tabella, si ricava  $f_c$  da introdurre nelle formule precedenti:

Once  $Z_h$  is thus calculated, use the following table to select  $f_c$ :

Nachdem  $Z_h$  kalkuliert worden ist, dann kann  $f_c$  aus der folgenden Tabelle ausgelesen werden.

Tab. 1	$Z_h$		
	1000	1000 - 2000	2000 - 3000
$f_c$	1	1.2 - 1.5	1.5 - 2

### 1.4 VERIFICA TERMICA

Si deve individuare il valore del momento torcente massimo / potenza massima, applicabile, in modo continuativo, in ingresso al riduttore epicicloidale, tale per cui la temperatura del riduttore stesso non superi  $T_{max}=95^\circ\text{C}$  (massimo valore di temperatura raggiungibile nel caso di applicazioni standard). Tali valori devono risultare maggiori rispetto al momento torcente / potenza realmente applicati.

I massimi valori di coppia motrice / potenza applicabili in entrata al riduttore, in servizio continuativo, sono ricavabili dalle seguenti tabelle (tab. 2, tab. 3), in funzione del numero di stadi di riduzione e del numero di giri in entrata, considerata una temperatura ambiente  $T_0=20^\circ\text{C}$ .

### 1.4 TEMPERATURE CHECK

*It is necessary to determine the max. torque/max. power applicable at the planetary gearbox input, continuous duty, so that gearbox temperature does not exceed  $T_{max}=95^\circ\text{C}$  (maximum permitted temperature for standard applications). The max applicable values have to be higher than the torque/power actually applied. The maximum values of driving torque/power applicable at gearbox input, continuous duty, are listed in the following tables (table 2 and 3), depending on number of reduction stages, number of revolutions at input and considering an ambient temperature  $T_0 = 20^\circ\text{C}$ .*

### 1.4 TEMPERATURPRÜFUNG

Es muss berechnet werden, welches Maximaldrehmoment /welche Maximalleistung am Antrieb des Planetengetriebes im Dauerbetrieb angewendet werden darf, ohne dass die Getriebetemperatur über  $T_{max}=95^\circ\text{C}$  steigt (zulässige Maximaltemperatur bei Standardanwendungen). Der berechnete Wert muss höher als der wirklich angewendete Wert die maximal werte von Drehmoment / Leistung sein. Die Maximalwerte von Drehmoment / Leistung (Dauerbetrieb) werden in den folgenden Tabellen (Tab. 2 und Tab.3) angegeben. Die Werte hängen von Zahl der Übersetzungsstufen und der Umdrehungen am Antrieb ab dabei wird eine Umgebungstemperatur  $T_0=20^\circ\text{C}$  berücksichtigt.

## RIDUTTORI EPICICLOIDALI DI PRECISIONE

### Potenza / Power / Leistung [kW]

(Limite termico / Thermal capacities / Temperaturgrenze)

Tab. 2	Stadi Steps Stufenzahl	n <sub>1</sub> [min <sup>-1</sup> ]			
		900	1400	2800	3600
REP 75	1	4.5	4.4	4.0	3.5
	2	2.5	2.3	2.0	1.8
	3	1.9	1.8	1.5	1.4
REP 100	1	6.0	6.0	4.6	3.8
	2	3.5	3.3	2.5	2.0
	3	2.7	2.5	2.0	1.6
REP 125	1	9.0	8.5	6.2	4.7
	2	5.5	4.8	3.4	2.5
	3	4.0	3.7	2.8	2.0
REP 150	1	11.0	10.0	5.6	2.8
	2	6.1	5.5	2.6	1.0
	3	4.7	4.3	2.3	0.9

### Coppia / Torque / Drehmoment [Nm]

(Limite termico / Thermal capacities / Temperaturgrenze)

Tab. 3	Stadi Steps Stufenzahl	n <sub>1</sub> [min <sup>-1</sup> ]			
		900	1400	2800	3600
REP 75	1	48	30	14	9
	2	27	16	7	5
	3	20	12	5	4
REP 100	1	64	41	16	10
	2	37	23	9	5
	3	29	17	7	4
REP 125	1	96	58	21	12
	2	58	33	12	7
	3	42	25	10	5
REP 150	1	117	68	19	7
	2	65	38	9	3
	3	50	29	8	2

Nel caso in cui l'applicazione preveda l'utilizzo di una coppia motrice / potenza maggiore del valore limite riportato nella tabella precedente, occorre valutare il massimo tempo di utilizzo, t<sub>max</sub> (s), del riduttore, in servizio continuo, affinché la temperatura non superi il valore T<sub>max</sub>=95°C.

A tal fine: il massimo tempo di utilizzo, t<sub>max</sub>, è ricavabile dalla seguente relazione:

*In case the application requires a driving torque/power higher than the max. permitted values reported in the table above, it is necessary to calculate the maximum length of operation, t<sub>max</sub> (s), of the gearbox in continuous duty so that temperature does not exceed T<sub>max</sub>=95°C.*

*The max. duration of operation, t<sub>max</sub>, is to be calculated as follows:*

Falls der verlangte Wert von Drehmoment / Leistung höher als der in den o.g. Tabellen angegebenen Wert ist, ist es notwendig, die maximale Anwendungsdauer t<sub>max</sub> (s) im Dauerbetrieb zu bestimmen, damit die Temperatur unter T<sub>max</sub>=95°C bleibt.

Die maximale Anwendungsdauer t<sub>max</sub> ist wie folgt zu berechnen:

$$t_{max} = c \ln \frac{T_s}{T_0} \frac{T_{MAX}}{T_0} \quad [s]$$

Dove:

T<sub>MAX</sub> = 95 °C (temperatura massima raggiungibile dal riduttore)  
 T<sub>0</sub> = temperatura ambiente (°C)  
 c = costante di tempo (s) ricavabile consultando la seguente tabella (Tab. 4):

Where:

T<sub>MAX</sub> = 95 °C (maximum permitted temperature)  
 T<sub>0</sub> = ambient temperature (°C)  
 c = time constant (s), as reported in the following table (Tab. 4):

Wobei:

T<sub>MAX</sub> = 95 °C (zulässige Maximaltemperatur des Getriebes)  
 T<sub>0</sub> = Umgebungstemperatur (C°)  
 c = Zeitkonstante, aus der folgenden Tabelle erhältlich (Tab. 4):

Tab. 4	REP 75			REP 100			REP 125			REP 150		
Stadi Steps Stufenzahl	1	2	3	1	2	3	1	2	3	1	2	3
c (s)	Costante di tempo / Time constant / Zeitkonstante											
	551	655	748	747	939	1111	1255	1590	1891	1858	2369	2824

T<sub>s</sub> = temperatura massima (°C) alla quale il riduttore tenderà a stabilizzarsi nel caso in cui sia applicata in ingresso la potenza P1, in condizioni di funzionamento continuo. Il valore di T<sub>s</sub> è ricavabile dalla seguente formula:

*T<sub>s</sub> = maximum temperature (°C) at which the gearbox will tend to stabilize in case P1 power is applied at input, continuous duty. Calculate T<sub>s</sub> value with the following formula:*

T<sub>s</sub> = maximale Temperatur (C°), auf die das Getriebe sich stabilisieren wird, falls im Dauerbetrieb P1 Antriebsleistung angewendet wird. T<sub>s</sub> ist mit der folgenden Formel zu berechnen:

$$T_s = T_0 + \frac{P_0}{C} \frac{P}{f_v} \quad [°C]$$



## RIDUTTORI EPICICLOIDALI DI PRECISIONE

in cui:  
 $P_0$  = potenza persa a vuoto (W), ricavabile dalla seguente tabella (Tab. 5) in funzione della grandezza del riduttore, del numero degli stadi di riduzione e della velocità di rotazione in ingresso

Where:  
 $P_0$  = *loadless friction power (W), reported in the following table (Tab. 5), depending on gearbox size, number of reduction stages and input rotation speed*

Wobei:  
 $P_0$  = *Verlustleistung ohne Last (W), ist aus der folgenden Tabelle zu entnehmen und hängt von Getriebegröße, Stufenzahl und Antriebsdrehzahl ab.*

Tab. 5

	$n_1= 900$ [min <sup>-1</sup> ]			$n_1= 1400$ [min <sup>-1</sup> ]			$n_1= 2800$ [min <sup>-1</sup> ]			$n_1= 3600$ [min <sup>-1</sup> ]		
	Stadi / Steps / Stufenzahl											
	1	2	3	1	2	3	1	2	3	1	2	3
	$P_0$ - Potenza persa a vuoto / <i>Loadless friction power</i> / Verlustleistung ohne Last [W]											
<b>REP 75</b>	3	4	5	6	8	8	14	18	19	20	26	27
<b>REP 100</b>	7	9	9	12	15	16	30	38	39	42	53	55
<b>REP 125</b>	12	15	16	22	27	28	56	71	73	81	101	104
<b>REP 150</b>	22	27	28	39	50	51	106	132	136	151	191	196

C = Coefficiente di dispersione termica, ricavabile dalla seguente tabella (Tab.6), in funzione della grandezza del riduttore

C = *loss of heat coefficient, listed in the following table (Tab. 6), according to gearbox size.*

C = *Wärmeverlustkoeffizient, wird in der folgenden Tabelle (Tab.6) angegeben und hängt von Getriebegröße ab.*

Tab. 6

	Stadi / Steps / Stufenzahl		
	1	2	3
	C - Coefficiente di dispersione termica / <i>loss of heat coefficient</i> / Wärmeverlustkoeffizient		
<b>REP 75</b>	1.024	1.120	1.248
<b>REP 100</b>	1.410	1.620	1.800
<b>REP 125</b>	2.175	2.450	2.725
<b>REP 150</b>	2.680	3.020	3.380

$f_v$  = fattore di ventilazione  
 1.45 con ventilazione forzata efficace con ventola dedicata  
 1.25 con ventilazione forzata secondaria ad altri dispositivi (pulegge, ventole motore, ecc.)  
**1 refrigerazione naturale (situazione standard)**  
 0.5 in ambiente chiuso e ristretto (carter)

$f_v$  = *ventilation factor*  
 1.45 for forced ventilation effective with special fan  
 1.25 for forced ventilation secondary to other devices (pulleys, motor fans, etc.)  
**1 for natural cooling (standard situation)**  
 0.5 in a close and narrow place (case)

$f_v$  = *Lüftungsfaktor*  
 1.45 für wirksame Drücklüftung mit Sonderlaufrad  
 1.25 für Drücklüftung zweitrangig zu anderen Vorrichtungen (Scheiben, Motorlaufräder, u.s.w.)  
**1 für Naturlüftung (Standardsituation)**  
 0.5 in geschlossenem und engem Raum (Gehäuse)

P = potenza persa proporzionale alla potenza applicata (W)  
 $P1 \cdot 0.015$  (W) nel caso di 1 stadio di riduzione  
 $P1 \cdot 0.03$  (W) nel caso di 2 stadi di riduzione  
 $P1 \cdot 0.044$  (W) nel caso di 3 stadi di riduzione

P = *friction power proportional to the applied power (W)*  
 $P1 \cdot 0.015$  (W) in case of 1 reduction stage  
 $P1 \cdot 0.03$  (W) in case of 2 reduction stages  
 $P1 \cdot 0.044$  (W) in case of 3 reduction stages

P = *Verlustleistung proportional to der angewandten Leistung (W)*  
 $P1 \cdot 0.015$  (W) im Falle von 1 Übersetzungsstufe  
 $P1 \cdot 0.03$  (W) im Falle von 2 Übersetzungsstufen  
 $P1 \cdot 0.044$  (W) im Falle von 3 Übersetzungsstufen

$P1$  è la potenza applicata in ingresso, da esprimersi in W. Nel caso in cui sia invece nota la coppia motrice applicata in ingresso  $T1$ , in Nm, si ricava il corrispondente valore di potenza, attraverso la relazione :

*$P1$  is the power applied at gearbox input and is expressed in W. In case one only knows  $T1$  (driving torque applied at input) expressed in Nm, the corresponding power value can be obtained as follows:*

$P1$  ist die am Getriebeantrieb angewandte Leistung und wird in W ausgedrückt. Falls nur  $T1$  (Antriebsdrehmoment in Nm) bekannt ist, dann ist den entsprechenden Leistungswert mit der folgenden Formel zu berechnen:

$$P1 = \frac{T1 \cdot n_1}{9550} \cdot 1000 \text{ [W]}$$

con  $n_1$  velocità di rotazione in ingresso in min<sup>-1</sup>.  
 Se il ciclo di lavoro è variabile nel tempo, si determinino i valori della coppia media  $T1_E$  e velocità media in ingresso  $n1_E$  secondo le seguenti formule:

*where  $n_1$  is the input rotation speed in min<sup>-1</sup>. If the operation cycle changes in time, the values of  $T1_E$  (average torque) and  $n1_E$  (average input speed) can be determined with the following formulae:*

Dabei ist  $n_1$  die Antriebsdrehzahl in min<sup>-1</sup>. Falls der Betriebszyklus in Laufe der Zeit wechselnd ist, dann sind Durchschnittsdrehmoment  $T1_E$  und Durchschnittsdrehzahl am Antrieb  $n1_E$  mit der folgenden Formel zu berechnen:

$$T1_E = \sqrt[3]{\frac{T1_{MAX}^3 \cdot n_{1m} \cdot t_a \dots T1_n^3 \cdot n_{1n} \cdot t_n}{t_a \cdot n_{1m} \dots t_n \cdot n_{1n}}} \text{ [Nm]}$$

$T1_n, n1_n, t_n$  = valori riferiti allo step ennesimo = *values referred to nth step.*  
 = Werte mit Bezug auf n-te Stufe.

$$n1_E = \frac{n_{1m} \cdot t_a \dots n_{1n} \cdot t_n}{t_a \dots t_n} \text{ [min}^{-1}\text{]}$$

## RIDUTTORI EPICICLOIDALI DI PRECISIONE

### 1.5 GIOCO ANGOLARE ( $\max$ )

Gioco massimo [arcmin] misurato sull'albero uscita, con albero entrata bloccato applicando una coppia pari al 2% della coppia nominale.

### 1.5 BACKLASH ( $\max$ )

Max. backlash measured on output shaft with torque equal to 2% of the nominal torque value with input shaft blocked.

### 1.5 WINKELSPIEL ( $\max$ )

Maximales Winkelspiel [arcmin], gemessen an der Abtriebswelle bei blockierter Eingangswelle mit Drehmoment gleich 2% des Nennmoments.

### 1.6 CARICHI RADIALI E ASSIALI SU ALBERO LENTO

Nella tabella delle prestazioni sono indicati i valori, espressi in N, dei carichi assiali e radiali ammissibili alle diverse velocità per una durata dei cuscinetti di 20000 ore. Il carico radiale  $F_{R2}$  si considera applicato ad una distanza dalla battuta pari alla metà della lunghezza dell'albero lento. Per distanze  $y$  diverse, è possibile calcolare il nuovo carico massimo ammissibile  $F_{R2Y}$  utilizzando formula e coefficienti indicati nella tabella.

### 1.6 RADIAL AND AXIAL LOADS ON OUTPUT SHAFT

The table of performances shows admissible axial and radial load values expressed in N for different speeds and for a bearing life of 20000 hours. Radial load  $F_{R2}$  calculations have been based on loads applied to halfway the output shaft extension. For different  $y$  distance it is possible to calculate the new maximum admissible load by using formula and coefficient shown in the table.

### 1.6 RADIAL-UND AXIALLASTEN AN DER AUSGANGSWELLE

Die Leistungstabelle enthält die in N ausgedrückten Werte der Axial- und Radiallasten für verschiedene Umdrehungszahlen. Diesen Werten liegt eine Lebensdauer der Lager von 20000 Stunden zugrunde. Die Radiallast  $F_{R2}$  greift hierbei auf der Mitte der Abtriebswelle an. Falls  $Y$ -distanz anders ist, ist die Zulässige radiallyast  $F_{R2Y}$  mit den in der Tabelle angegebenen formel und Koeffizient zu berechnen:

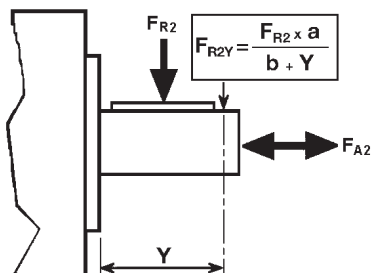

	REP 75	REP 100	REP 125	REP 150
a	46	55	85	102
b	30	37	51	61

### 1.7 LUBRIFICAZIONE

I riduttori REP sono forniti completi di lubrificante a vita pertanto non necessitano di manutenzione. In fase di ordine specificare la posizione di montaggio.

### 1.7 LUBRICATION

REP gearboxes are supplied filled with long-life lubricant and do not require any maintenance. When ordering it is important to specify the exact mounting position.

### 1.7 SCHMIERUNG

Die REP Planetengetriebe werden inklusiv Dauerschmierung geliefert und sind wartungsfrei. Bei der Bestellung bitte die Einbauposition angeben.

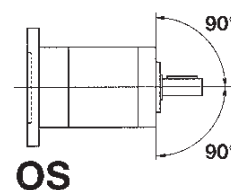
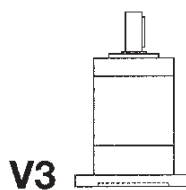
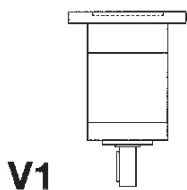
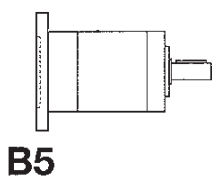

**RIDUTTORI EPICICLOIDALI DI PRECISIONE****1.8 MOMENTO D'INERZIA J**  
[kg·cm<sup>2</sup>]**1.8 MOMENT OF INERTIA J**  
[kg·cm<sup>2</sup>]**1.8 TRÄGHEITSMOMENT J**  
[kg·cm<sup>2</sup>]

		<b>REP 075</b>									
		Albero entrata / Input shaft / Antriebswelle									
Stadi Steps Stufenzahl	i	6	6.35	7	8	9	9.52	11	12	12.7	14
1	3	0.163	0.163	0.163	0.187	0.187	0.186	0.208	0.211	0.209	0.247
	4	0.137	0.137	0.137	0.161	0.161	0.160	0.182	0.185	0.183	0.221
	5	0.116	0.116	0.115	0.140	0.139	0.139	0.161	0.164	0.162	0.200
	6	0.108	0.108	0.108	0.133	0.132	0.131	0.154	0.156	0.155	0.193
2	9	0.164	0.164	0.164	0.188	0.188	0.187	0.209	0.212	0.210	0.248
	12	0.161	0.161	0.161	0.185	0.185	0.184	0.207	0.209	0.207	0.245
	16	0.135	0.135	0.135	0.160	0.159	0.158	0.181	0.183	0.182	0.220
	20	0.115	0.115	0.115	0.139	0.139	0.138	0.160	0.163	0.161	0.199
	24	0.108	0.108	0.108	0.132	0.132	0.131	0.153	0.156	0.154	0.192
	30	0.107	0.107	0.107	0.131	0.131	0.130	0.153	0.155	0.154	0.191
3	36	0.107	0.107	0.107	0.131	0.131	0.130	0.152	0.155	0.153	0.191
	27	0.164	0.164	0.164	0.188	0.188	0.187	0.210	0.212	0.210	0.248
	36	0.164	0.164	0.164	0.188	0.188	0.187	0.209	0.212	0.210	0.248
	48	0.161	0.161	0.161	0.185	0.185	0.184	0.206	0.209	0.207	0.245
	64	0.135	0.135	0.135	0.159	0.159	0.158	0.181	0.183	0.182	0.220
	80	0.115	0.115	0.114	0.139	0.138	0.138	0.160	0.163	0.161	0.199
	100	0.114	0.114	0.114	0.138	0.138	0.137	0.159	0.162	0.160	0.198
	120	0.107	0.107	0.107	0.131	0.131	0.130	0.153	0.155	0.153	0.191
144	0.107	0.107	0.107	0.131	0.131	0.130	0.152	0.155	0.153	0.191	
180	0.107	0.107	0.107	0.131	0.131	0.130	0.152	0.155	0.153	0.191	
216	0.107	0.107	0.107	0.131	0.131	0.130	0.152	0.155	0.153	0.191	

		<b>REP 100</b>							
		Albero entrata / Input shaft / Antriebswelle							
Stadi Steps Stufenzahl	i	9	9.52	11	12.7	14	15.87	16	19
1	3	0.466	0.465	0.486	0.487	0.529	0.816	0.816	0.803
	4	0.350	0.349	0.370	0.371	0.413	0.700	0.700	0.687
	5	0.279	0.278	0.299	0.300	0.343	0.630	0.629	0.616
	6	0.257	0.257	0.278	0.279	0.321	0.608	0.608	0.595
2	9	0.484	0.483	0.504	0.505	0.547	0.834	0.834	0.821
	12	0.470	0.469	0.490	0.491	0.534	0.821	0.820	0.807
	16	0.342	0.342	0.362	0.363	0.406	0.693	0.692	0.680
	20	0.277	0.277	0.297	0.298	0.341	0.628	0.627	0.615
	24	0.256	0.255	0.276	0.277	0.320	0.607	0.606	0.593
	30	0.254	0.254	0.274	0.275	0.318	0.605	0.604	0.592
3	36	0.254	0.253	0.274	0.275	0.317	0.604	0.604	0.591
	27	0.486	0.485	0.506	0.507	0.549	0.836	0.836	0.823
	36	0.484	0.483	0.504	0.505	0.548	0.835	0.834	0.822
	48	0.470	0.469	0.490	0.491	0.534	0.821	0.820	0.807
	64	0.342	0.342	0.362	0.363	0.406	0.693	0.692	0.680
	80	0.277	0.277	0.297	0.298	0.341	0.628	0.627	0.615
	100	0.275	0.274	0.295	0.296	0.338	0.625	0.625	0.612
	120	0.254	0.253	0.274	0.275	0.318	0.605	0.604	0.592
	144	0.254	0.253	0.274	0.275	0.317	0.604	0.604	0.591
	180	0.254	0.253	0.274	0.275	0.317	0.604	0.604	0.591
216	0.254	0.253	0.274	0.275	0.317	0.604	0.604	0.591	

I valori dei momenti d'inerzia riportati si riferiscono all'albero entrata.

*The moment of inertia values refer to the input shaft.*

Die Werte der Trägheitsmoment beziehen sich auf die Antriebswelle.

**RIDUTTORI EPICICLOIDALI DI PRECISIONE****1.8 MOMENTO D'INERZIA J**  
[kg·cm<sup>2</sup>]**1.8 MOMENT OF INERTIA J**  
[kg·cm<sup>2</sup>]**1.8 TRÄGHEITSMOMENT J**  
[kg·cm<sup>2</sup>]

		<b>REP 125</b>							
		Albero entrata / Input shaft / Antriebswelle							
Stadi Steps Stufenzahl	i	12.7	14	15.87	16	19	22	24	28
<b>1</b>	<b>3</b>	1.914	1.980	2.264	2.263	2.236	4.951	4.909	5.097
	<b>4</b>	1.180	1.246	1.530	1.530	1.503	4.218	4.176	4.363
	<b>5</b>	0.839	0.905	1.189	1.189	1.162	3.877	3.835	4.022
	<b>7</b>	0.636	0.701	0.986	0.985	0.958	3.673	3.631	3.818
<b>2</b>	<b>9</b>	1.928	1.994	2.278	2.277	2.251	4.965	4.923	5.111
	<b>12</b>	1.847	1.912	2.197	2.196	2.169	4.884	4.842	5.029
	<b>16</b>	1.143	1.208	1.492	1.492	1.465	4.180	4.138	4.325
	<b>20</b>	0.815	0.881	1.165	1.164	1.138	3.852	3.810	3.998
	<b>28</b>	0.623	0.689	0.973	0.973	0.946	3.660	3.619	3.806
	<b>35</b>	0.626	0.692	0.976	0.976	0.949	3.663	3.622	3.809
<b>3</b>	<b>49</b>	0.622	0.688	0.972	0.971	0.945	3.659	3.617	3.805
	<b>36</b>	1.922	1.988	2.272	2.271	2.244	4.959	4.917	5.105
	<b>48</b>	1.843	1.909	2.193	2.192	2.166	4.880	4.838	5.026
	<b>64</b>	1.141	1.206	1.491	1.490	1.463	4.178	4.136	4.323
	<b>80</b>	0.814	0.880	1.164	1.163	1.136	3.851	3.809	3.997
	<b>100</b>	0.801	0.867	1.151	1.151	1.124	3.838	3.797	3.984
	<b>140</b>	0.616	0.682	0.966	0.966	0.939	3.653	3.612	3.799
	<b>196</b>	0.612	0.678	0.962	0.962	0.935	3.649	3.608	3.795
<b>245</b>	0.612	0.677	0.962	0.961	0.934	3.649	3.607	3.794	
<b>343</b>	0.612	0.677	0.961	0.961	0.934	3.649	3.607	3.794	

		<b>REP 150</b>								
		Albero entrata / Input shaft / Antriebswelle								
Stadi Steps Stufenzahl	i	15.87	16	19	22	24	28	32	35	38
<b>1</b>	<b>3</b>	6.577	6.576	6.617	7.565	7.527	11.554	13.382	13.281	12.943
	<b>4</b>	4.637	4.637	4.677	5.625	5.587	9.615	11.442	11.341	11.003
	<b>5</b>	3.643	3.642	3.683	4.631	4.593	8.620	10.448	10.347	10.009
	<b>7</b>	3.054	3.053	3.093	4.042	4.004	8.031	9.858	9.758	9.420
<b>2</b>	<b>9</b>	6.537	6.536	6.576	7.525	7.487	11.514	13.341	13.241	12.903
	<b>12</b>	6.321	6.321	6.361	7.309	7.271	11.299	13.126	13.025	12.687
	<b>16</b>	4.494	4.493	4.533	5.482	5.444	9.471	11.298	11.197	10.860
	<b>20</b>	3.551	3.550	3.590	4.539	4.501	8.528	10.356	10.255	9.917
	<b>28</b>	3.007	3.006	3.046	3.995	3.957	7.984	9.811	9.711	9.373
	<b>35</b>	2.986	2.985	3.026	3.974	3.936	7.964	9.791	9.690	9.352
<b>3</b>	<b>49</b>	2.974	2.973	3.014	3.962	3.924	7.951	9.779	9.678	9.340
	<b>36</b>	6.508	6.508	6.548	7.496	7.458	11.486	13.313	13.212	12.874
	<b>48</b>	6.305	6.305	6.345	7.293	7.255	11.283	13.110	13.009	12.671
	<b>64</b>	4.485	4.484	4.524	5.473	5.435	9.462	11.289	11.189	10.851
	<b>80</b>	3.545	3.544	3.585	4.533	4.495	8.523	10.350	10.249	9.911
	<b>100</b>	3.507	3.506	3.546	4.495	4.457	8.484	10.311	10.211	9.873
	<b>140</b>	2.984	2.984	3.024	3.972	3.934	7.962	9.789	9.688	9.350
	<b>196</b>	2.973	2.972	3.013	3.961	3.923	7.951	9.778	9.677	9.339
<b>245</b>	2.973	2.972	3.012	3.961	3.923	7.950	9.777	9.677	9.339	
<b>343</b>	2.972	2.972	3.012	3.960	3.922	7.950	9.777	9.676	9.338	

I valori dei momenti d'inerzia riportati si riferiscono all'albero entrata.

*The moment of inertia values refer to the input shaft.*

Die Werte der Trägheitsmoment beziehen sich auf die Antriebswelle.

# REP075 RIDUTTORI EPICICLOIDALI DI PRECISIONE

## 1.9 DATI TECNICI

## 1.9 TECHNICAL DATA

## 1.9 TECHNISCHE DATEN

Stadi Steps Stufenzahl	1				2								3									
i	3	4	5	6	9	12	16	20	24	30	36	27	36	48	64	80	100	120	144	180	216	
$n_{1\text{ nom}}$	4000				4500								5000									
$n_{1\text{ max}}$	6000																					
$T_{2N}$	35	45	35	30	40	50	50	50	50	40	35	40	55	55	55	55	55	55	55	40	35	
$T_{2A}$	55	65	55	50	60	70	70	70	70	60	55	60	80	80	80	80	80	80	80	60	55	
$T_{2S}$	110	130	110	100	120	140	140	140	140	120	110	120	150	150	150	150	150	150	150	120	110	
<b>J</b>	Vedi pag. 9 / See on page 9 / Siehe Seite 9																					
<b>LpA</b>	< 70																					
$R_d$	0.96				0.93								0.91									
$L_h$	20000																					
$F_{R2}$	1400																					
$F_{A2}$	700																					
$R_t$	4																					
$\text{max}$	4'				6'								8'									
<b>Kg</b>	1.3				1.6								1.9									

<b>i</b>	Rapporto di riduzione nominale	<i>Nominal ratio</i>	Nenn-Untersetzungsverhältnis
$n_{1\text{ nom}}$	Velocità nominale in entrata [ $\text{min}^{-1}$ ]	<i>Nominal input speed [<math>\text{min}^{-1}</math>]</i>	Nenn-Eingangsdrehzahl [ $\text{min}^{-1}$ ]
$n_{1\text{ max}}$	Velocità massima in entrata [ $\text{min}^{-1}$ ]	<i>Maximum input speed [<math>\text{min}^{-1}</math>]</i>	Maximale Eingangsdrehzahl [ $\text{min}^{-1}$ ]
$T_{2N}$	Coppia nominale intermittente in uscita [Nm]	<i>Rated intermittent output torque [Nm]</i>	Nenn-Abtriebsmoment (im Aussetzbetrieb) [Nm]
$T_{2A}$	Coppia massima di accelerazione in uscita [Nm]	<i>Maximum acceleration output torque [Nm]</i>	Maximales Beschleunigungsmoment am Abtrieb [Nm]
$T_{2S}$	Coppia massima di emergenza in uscita [Nm]	<i>Maximum emergency output torque [Nm]</i>	Maximale Überlast am Abtrieb [Nm]
<b>LpA</b>	Livello di rumorosità dB(A) a $3000\text{ min}^{-1}$	<i>Noise level dB(A) at <math>3000\text{ min}^{-1}</math></i>	Geräuschpegel dB(A) bei $3000\text{ min}^{-1}$
<b>Rd</b>	Rendimento dinamico	<i>Dynamic efficiency</i>	Dynamischer Wirkungsgrad
$L_h$	Durata cuscinetti [h]	<i>Bearing life [h]</i>	Lebensdauer der Lager [h]
$F_{R2}$	Carico radiale nominale in uscita [N] a $300\text{min}^{-1}$	<i>Rated output radial load [N] at <math>300\text{min}^{-1}</math></i>	Nenn-Radiallast an der Abtriebswelle bei $300\text{min}^{-1}$
$F_{A2}$	Carico assiale in uscita [N] a $300\text{min}^{-1}$	<i>Output axial load [N] at <math>300\text{min}^{-1}</math></i>	Axiallast an der Abtriebswelle bei $300\text{min}^{-1}$
$R_t$	Rigidità torsionale [Nm / arcmin]	<i>Torsional rigidity [Nm / arcmin]</i>	Drehfestigkeit [Nm / arcmin]
$\text{max}$	Gioco angolare massimo [arcmin]	<i>Maximum backlash [arcmin]</i>	Maximale Winkelspiel [arcmin]
<b>J</b>	Momento d'inerzia [ $\text{kg}\cdot\text{cm}^2$ ]	<i>Moment of inertia [<math>\text{kg}\cdot\text{cm}^2</math>]</i>	Traegheitsmoment [ $\text{kg}\cdot\text{cm}^2$ ]

## 1.10 DIMENSIONI

## 1.10 DIMENSIONS

## 1.10 ABMESSUNGEN

Dimensioni generali e uscite / General and output dimensions / General-und Abtriebsabmessungen

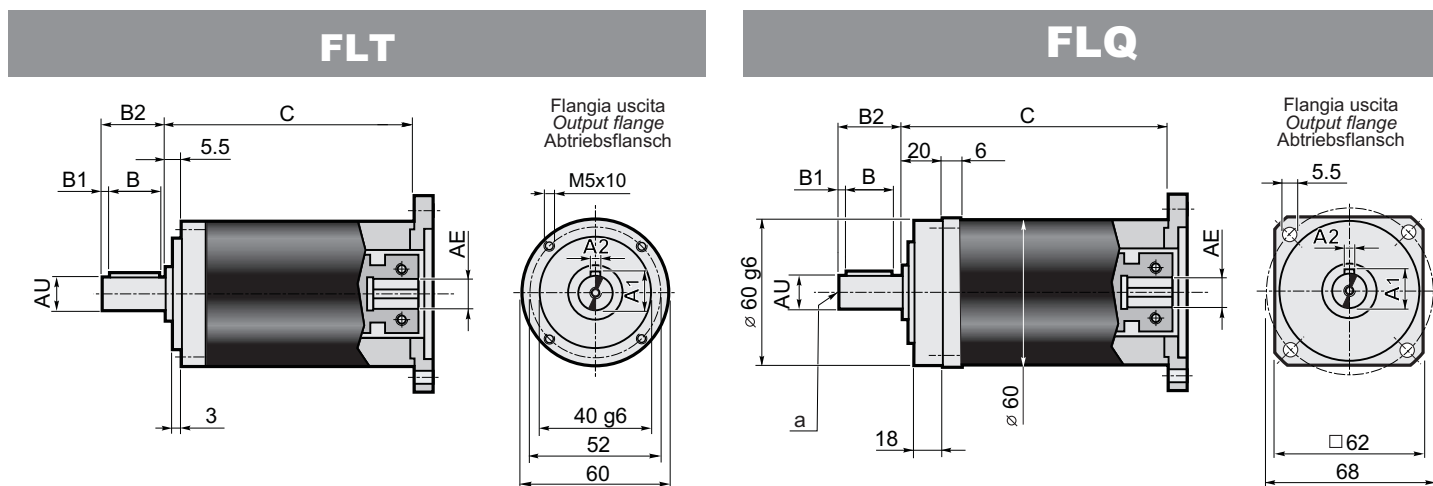

Stadi/Steps/Stufenzahl	1	2	3	
<b>C</b>	83.2	100.9	118.6	AE= 6-6.35-7-8-9-9.52 11-12-12.7-14

	Albero uscita - Output shaft - Abtriebswelle						
	AU j6	A1	A2	B	B1	B2	a
<b>AU12</b>		13.5	4	15	3	21	M4x10
<b>AU14</b>	14	16	5	25	2	28	M5x13
<b>AU16</b>	16	18	5	25	2	28	M5x13

# RIDOTTORI EPICICLOIDALI DI PRECISIONE **REP075**

Dimensioni entrate

Input dimensions

Antriebsabmessungen

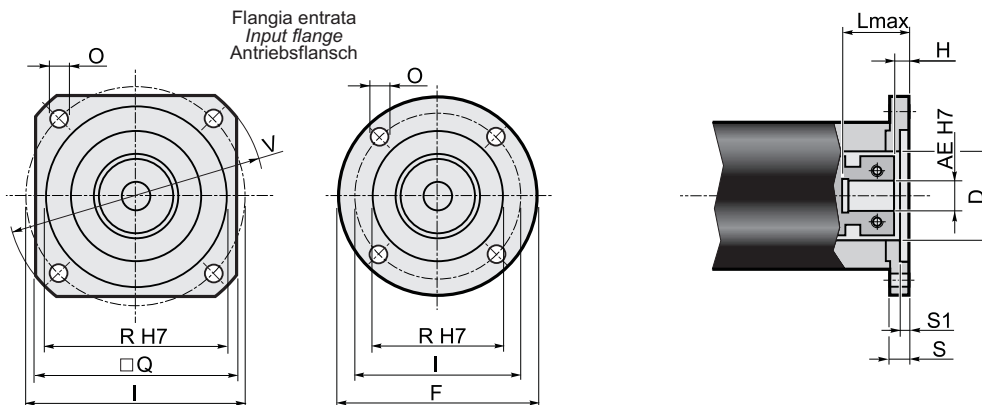

	Flange entrata / Input flange / Antriebsflansch								Albero entrata / Input shaft / Antriebswelle																				
									AE																				
									6		6.35		7		8		9		9.52		11		12		12.7		14		
F	Q	V	I	R (H7)	O	S	S1	D	L <sub>max</sub>	H	L <sub>max</sub>	H	L <sub>max</sub>	H	L <sub>max</sub>	H	L <sub>max</sub>	H	L <sub>max</sub>	H	L <sub>max</sub>	H	L <sub>max</sub>	H	L <sub>max</sub>	H			
P01*	60	=	=	43.82	22	4.5	10	3	22	34	3.5	34	3.5	34	3.5	25	5.5	25	5.5	34	5.5	25	5.5	34	5.5	34	5.5	34	5.5
P02*	=	60	80	66.67	38.1	5.5	10	3	32	34	3.5	34	3.5	34	3.5	25	5.5	25	5.5	34	5.5	25	5.5	34	5.5	34	5.5	34	5.5
P03*	=	60	80	63	40	5.5	10	3.5	32	34	3.5	34	3.5	34	3.5	25	5.5	25	5.5	34	5.5	25	5.5	34	5.5	34	5.5	34	5.5
P04	=	70	90	75	60	6.5	10.5	3.5	32	34.5	4	34.5	4	34.5	4	25.5	6	25.5	6	34.5	6	25.5	6	34.5	6	34.5	6	34.5	6
P05	105	=	=	85	70	6.5	10.5	3.5	32	34.5	4	34.5	4	34.5	4	25.5	6	25.5	6	34.5	6	25.5	6	34.5	6	34.5	6	34.5	6
P06	=	80	110	98.42	73.02	6	11	3.5	35	35	4.5	35	4.5	35	4.5	26	6.5	26	6.5	35	6.5	26	6.5	35	6.5	35	6.5	35	6.5
P07	=	95	120	100	80	6.5	11.5	4	32	35.5	5	35.5	5	35.5	5	26.5	7	26.5	7	35.5	7	26.5	7	35.5	7	35.5	7	35.5	7
P08	=	98	130	115	95	9	11.5	4	32	35.5	5	35.5	5	35.5	5	26.5	7	26.5	7	35.5	7	26.5	7	35.5	7	35.5	7	35.5	7
P09	=	116	160	130	110	9	12	4.5	32	36	5.5	36	5.5	36	5.5	27	7.5	27	7.5	36	7.5	27	7.5	36	7.5	36	7.5	36	7.5
P10*	60	=	=	39	26	4.5	10	3	26	34	3.5	34	3.5	34	3.5	25	5.5	25	5.5	34	5.5	25	5.5	34	5.5	34	5.5	34	5.5
P11*	60	=	=	42	32	4.5	10	3	32	34	3.5	34	3.5	34	3.5	25	5.5	25	5.5	34	5.5	25	5.5	34	5.5	34	5.5	34	5.5
P12*	65	=	=	46	32	4.5	10	3.5	32	34	3.5	34	3.5	34	3.5	25	5.5	25	5.5	34	5.5	25	5.5	34	5.5	34	5.5	34	5.5
P13*	80	=	=	65	50	5.5	10	3.5	32	34	3.5	34	3.5	34	3.5	25	5.5	25	5.5	34	5.5	25	5.5	34	5.5	34	5.5	34	5.5
P14*	60	=	=	39	20	4.5	10	2.5	20	34	3.5	34	3.5	34	3.5	25	5.5	25	5.5	34	5.5	25	5.5	34	5.5	34	5.5	34	5.5
P15	=	75	100	90	60	5.8	12	3.5	32	36	5.5	36	5.5	36	5.5	27	7.5	27	7.5	36	7.5	27	7.5	36	7.5	36	7.5	36	7.5
P16*	60	=	=	45	30	3.5	14	7	30	38	7.5	38	7.5	38	7.5	29	9.5	29	9.5	38	9.5	29	9.5	38	9.5	38	9.5	38	9.5
P17	=	60	82	70	50	4.5	16.5	8	32	40.5	10	40.5	10	40.5	10	31.5	12	31.5	12	40.5	12	31.5	12	40.5	12	40.5	12	40.5	12
P18	=	60	80	60	50	M4	10.5	3.5	32	34.5	4	34.5	4	34.5	4	25.5	6	25.5	6	34.5	6	25.5	6	34.5	6	34.5	6	34.5	6
P19*	60	=	=	36	25	4.5	10	3	25	34	3.5	34	3.5	34	3.5	25	5.5	25	5.5	34	5.5	25	5.5	34	5.5	34	5.5	34	5.5
P20	=	60	82	70	50	5.5	10.5	3.5	32	34.5	4	34.5	4	34.5	4	25.5	6	25.5	6	34.5	6	25.5	6	34.5	6	34.5	6	34.5	6
P21*	60	=	=	46	30	4.5	10	3	30	34	3.5	34	3.5	34	3.5	25	5.5	25	5.5	34	5.5	25	5.5	34	5.5	34	5.5	34	5.5
P22	=	60	80	70.71	36	4.5	10	2	32	34	3.5	34	3.5	34	3.5	25	5.5	25	5.5	34	5.5	25	5.5	34	5.5	34	5.5	34	5.5
P23	=	62	85	70	50	5.5	15.5	3.5	32	39.5	9	39.5	9	39.5	9	30.5	11	30.5	11	39.5	11	30.5	11	39.5	11	39.5	11	39.5	11
P24	=	75	100	90	70	5.8	12	3.5	32	36	5.5	36	5.5	36	5.5	27	7.5	27	7.5	36	7.5	27	7.5	36	7.5	36	7.5	36	7.5
P25	=	70	95	85	55	5.8	12	3.5	32	36	5.5	36	5.5	36	5.5	27	7.5	27	7.5	36	7.5	27	7.5	36	7.5	36	7.5	36	7.5
P26*	=	60	80	65.5	34	5.5	10	3.5	33	34	3.5	34	3.5	34	3.5	25	5.5	25	5.5	34	5.5	25	5.5	34	5.5	34	5.5	34	5.5
P27	=	80	110	95	50	6.5	12	3.5	32	36	5.5	36	5.5	36	5.5	27	7.5	27	7.5	36	7.5	27	7.5	36	7.5	36	7.5	36	7.5
P28	=	60	80	66.67	38.1	M4	9	2.5	32	33	2.5	33	2.5	33	2.5	24	4.5	24	4.5	33	4.5	24	4.5	33	4.5	33	4.5	33	4.5
P29	60	=	=	45	30	M3	11	4	32	35	4.5	35	4.5	35	4.5	26	6.5	26	6.5	35	6.5	26	6.5	35	6.5	35	6.5	35	6.5
P30	=	70	95	85	60	5.8	12	3.5	32	36	5.5	36	5.5	36	5.5	27	7.5	27	7.5	36	7.5	27	7.5	36	7.5	36	7.5	36	7.5
P31	=	62	85	70	50	M4	11	3.5	32	35	4.5	35	4.5	35	4.5	26	6.5	26	6.5	35	6.5	26	6.5	35	6.5	35	6.5	35	6.5
P32	=	60	80	65	40	M5	10	3.5	32	34	3.5	34	3.5	34	3.5	25	5.5	25	5.5	34	5.5	25	5.5	34	5.5	34	5.5	34	5.5
P33	=	85	115	99	60	5.5	11	3.5	32	35	4.5	35	4.5	35	4.5	26	6.5	26	6.5	35	6.5	26	6.5	35	6.5	35	6.5	35	6.5
P34	=	65	87	73.54	40	M4	10	3.5	32	34	3.5	34	3.5	34	3.5	25	5.5	25	5.5	34	5.5	25	5.5	34	5.5	34	5.5	34	5.5

\* Per assemblare il motore è necessario smontare la flangia dal riduttore (vedere schema di montaggio 2 a pag. 21).

\* To mount the motor it is necessary to remove the gearbox flange (see assembly drawing 2 on page 21).

\* Vor dem Einbauen des Motors soll die Getriebeflangsch abmontiert werden (siehe Bauanleitung 2 auf Seite 21).

# REP100 RIDUTTORI EPICICLOIDALI DI PRECISIONE

## 1.9 DATI TECNICI

## 1.9 TECHNICAL DATA

## 1.9 TECHNISCHE DATEN

Stadi Steps Stufenzahl	1				2								3									
i	3	4	5	6	9	12	16	20	24	30	36	27	36	48	64	80	100	120	144	180	216	
<b>n<sub>1</sub> nom</b>	4000				4500								5000									
<b>n<sub>1</sub> max</b>	6000																					
<b>T<sub>2N</sub></b>	90	110	90	75	100	115	115	115	115	85	75	100	120	120	120	120	120	120	120	95	80	
<b>T<sub>2A</sub></b>	145	170	130	120	160	180	180	180	180	140	130	160	190	190	190	190	190	190	190	150	130	
<b>T<sub>2S</sub></b>	290	340	260	240	320	360	360	360	360	280	260	320	380	380	380	380	380	380	380	300	260	
<b>J</b>	Vedi pag. 9 / See on page 9 / Siehe Seite 9																					
<b>LpA</b>	< 70																					
<b>R<sub>d</sub></b>	0.96				0.93								0.91									
<b>L<sub>h</sub></b>	20000																					
<b>F<sub>R2</sub></b>	2100																					
<b>F<sub>A2</sub></b>	1050																					
<b>R<sub>t</sub></b>	11																					
<b>max</b>	4'				6'								8'									
<b>Kg</b>	2.7				3.5								4.3									

<b>i</b>	Rapporto di riduzione nominale	<i>Nominal ratio</i>	Nenn-Untersetzungsverhältnis
<b>n<sub>1</sub> nom</b>	Velocità nominale in entrata [min <sup>-1</sup> ]	<i>Nominal input speed [min<sup>-1</sup>]</i>	Nenn-Eingangsdrehzahl [min <sup>-1</sup> ]
<b>n<sub>1</sub> max</b>	Velocità massima in entrata [min <sup>-1</sup> ]	<i>Maximum input speed [min<sup>-1</sup>]</i>	Maximale Eingangsdrehzahl [min <sup>-1</sup> ]
<b>T<sub>2N</sub></b>	Coppia nominale intermittente in uscita [Nm]	<i>Rated intermittent output torque [Nm]</i>	Nenn-Abtriebsmoment (im Aussetzbetrieb)[Nm]
<b>T<sub>2A</sub></b>	Coppia massima di accelerazione in uscita [Nm]	<i>Maximum acceleration output torque [Nm]</i>	Maximales Beschleunigungsmoment am Abtrieb [Nm]
<b>T<sub>2S</sub></b>	Coppia massima di emergenza in uscita [Nm]	<i>Maximum emergency output torque [Nm]</i>	Maximale Überlast am Abtrieb [Nm]
<b>LpA</b>	Livello di rumorosità dB(A) a 3000 min <sup>-1</sup>	<i>Noise level dB(A) at 3000 min<sup>-1</sup></i>	Geräuschpegel dB(A) bei 3000 min <sup>-1</sup>
<b>R<sub>d</sub></b>	Rendimento dinamico	<i>Dynamic efficiency</i>	Dynamischer Wirkungsgrad
<b>L<sub>h</sub></b>	Durata cuscinetti [h]	<i>Bearing life [h]</i>	Lebensdauer der Lager [h]
<b>F<sub>R2</sub></b>	Carico radiale nominale in uscita [N] a 300min <sup>-1</sup>	<i>Rated output radial load [N] at 300min<sup>-1</sup></i>	Nenn-Radiallast an der Abtriebswelle bei 300min <sup>-1</sup>
<b>F<sub>A2</sub></b>	Carico assiale in uscita [N] a 300min <sup>-1</sup>	<i>Output axial load [N] at 300min<sup>-1</sup></i>	Axiallast an der Abtriebswelle bei 300min <sup>-1</sup>
<b>R<sub>t</sub></b>	Rigidità torsionale [Nm / arcmin]	<i>Torsional rigidity [Nm / arcmin]</i>	Drehfestigkeit [Nm / arcmin]
<b>J</b>	Gioco angolare massimo [arcmin]	<i>Maximum backlash [arcmin]</i>	Maximale Winkelspiel [arcmin]
<b>Kg</b>	Momento d'inerzia [kg·cm <sup>2</sup> ]	<i>Moment of inertia [kg·cm<sup>2</sup>]</i>	Traegheitsmoment [kg·cm <sup>2</sup> ]

## 1.10 DIMENSIONI

## 1.10 DIMENSIONS

## 1.10 ABMESSUNGEN

Dimensioni generali e uscite / *General and output dimensions* / General-und Abtriebsabmessungen

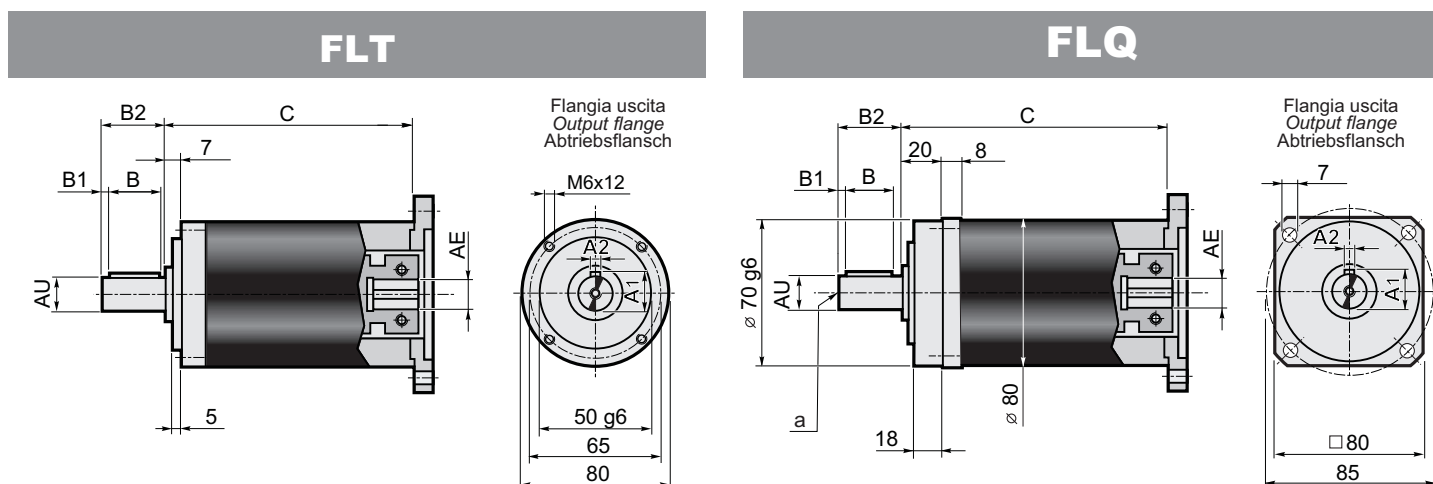

Stadi/Steps/Stufenzahl	1	2	3	
<b>C</b>	102	127	152.5	AE= 9-9.52-11-12.7 14-15.87-16-19

	Albero uscita - <i>Output shaft</i> - Abtriebswelle						
	AU j6	A1	A2	B	B1	B2	a
<b>AU19</b>	19	21.5	6	30	3	36	M6x16
<b>AU22</b>	22	24.5	6	30	3	36	M6x16

# RIDUTTORI EPICICLOIDALI DI PRECISIONE **REP100**

Dimensioni entrate

Input dimensions

Antriebsabmessungen

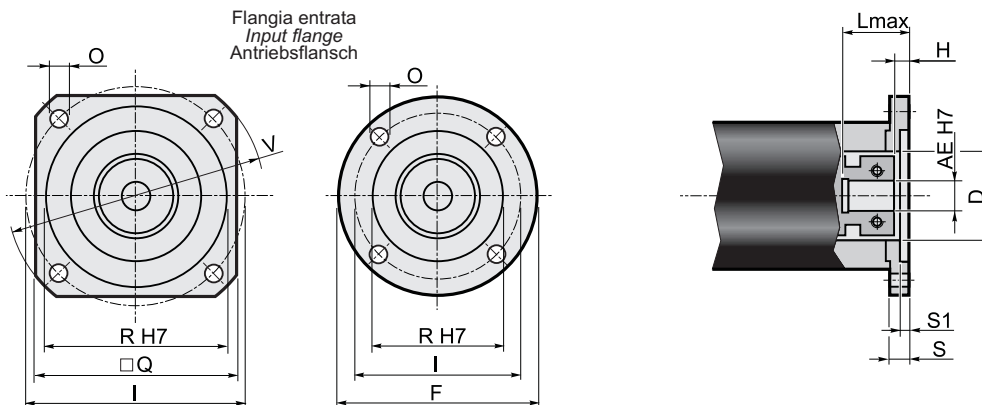

Flange entrata / Input flange / Antriebsflansch										Albero entrata - Input shaft - Antriebswelle															
										AE															
										9		9.525		11		12		12.7		14		15.87		16	
F	Q	V	I	R (H7)	O	S	S1	D	L <sub>max</sub>	H	L <sub>max</sub>	H	L <sub>max</sub>	H	L <sub>max</sub>	H	L <sub>max</sub>	H	L <sub>max</sub>	H	L <sub>max</sub>	H	L <sub>max</sub>	H	
P01*	80	=	=	66.67	38.1	5.5	12	3	38.1	41	3.5	41	6	26	6	41	6	41	6	41	6	41	6	41	6
P02	=	106.5	140	125.72	55.52	7	11	3	45	40	2.5	40	5	25	5	40	5	40	5	40	5	40	5	40	5
P03*	=	80	90	75	60	5.5	12	3.5	45	41	3.5	41	6	26	6	41	6	41	6	41	6	41	6	41	6
P04*	105	=	=	85	70	6.5	12	3.5	45	41	3.5	41	6	26	6	41	6	41	6	41	6	41	6	41	6
P05	=	82.5	110	98.425	73.02	6.5	12	3	45	41	3.5	41	6	26	6	41	6	41	6	41	6	41	6	41	6
P06	=	90	120	100	80	6.5	13	4	45	42	4.5	42	7	27	7	42	7	42	7	42	7	42	7	42	7
P07	=	100	135	115	95	8.5	13	4.5	45	42	4.5	42	7	27	7	42	7	42	7	42	7	42	7	42	7
P08	=	116	160	130	110	9	13	4.5	45	42	4.5	42	7	27	7	42	7	42	7	42	7	42	7	42	7
P09*	80	=	=	39	26	4.5	12	4	26	41	3.5	41	6	26	6	41	6	41	6	41	6	41	6	41	6
P10*	80	=	=	65	50	5.5	12	3.5	45	41	3.5	41	6	26	6	41	6	41	6	41	6	41	6	41	6
P11	=	150	182	166	115	9	32	11	50x14	61	23.5	61	26	46	26	61	26	61	26	61	26	61	26	61	26
P12*	=	80	105	90	70	6.5	12	3.5	32	41	3.5	41	6	26	6	41	6	41	6	41	6	41	6	41	6
P14	105	=	=	90	70	6	19	9	32	48	10.5	48	13	33	13	48	13	48	13	48	13	48	13	48	13
P15*	80	=	=	70	50	4.5	17	8	45	46	8.5	46	11	31	11	46	11	46	11	46	11	46	11	46	11
P16	=	142	190	165	130	11	13	4.5	45	42	4.5	42	7	27	7	42	7	42	7	42	7	42	7	42	7
P17*	80	=	=	63	40	5.5	12	3.5	40	41	3.5	41	6	26	6	41	6	41	6	41	6	41	6	41	6
P18	=	130	170	145	110	M8	31	7	32	60	22.5	60	25	45	25	60	25	60	25	60	25	60	25	60	25
P19*	=	80	105	90	60	6.5	12	3.5	32	41	3.5	41	6	26	6	41	6	41	6	41	6	41	6	41	6
P20*	=	80	105	85	55	5.5	12	3.5	36	41	3.5	41	6	26	6	41	6	41	6	41	6	41	6	41	6
P21	=	80	110	95	50	M6	12	3.5	45	41	3.5	41	6	26	6	41	6	41	6	41	6	41	6	41	6
P22	80	=	=	70	50	M4	12	4	45	41	3.5	41	6	26	6	41	6	41	6	41	6	41	6	41	6
P23	=	80	90	75	60	M5	12	3.5	45	41	3.5	41	6	26	6	41	6	41	6	41	6	41	6	41	6
P24	80	=	=	46	30	M4	12	4	30	41	3.5	41	6	26	6	41	6	41	6	41	6	41	6	41	6
P25	80	=	=	99	60	M6	12	3.5	45	41	3.5	41	6	26	6	41	6	41	6	41	6	41	6	41	6
P26	80	=	=	65	40	M5	12	3.5	40	41	3.5	41	6	26	6	41	6	41	6	41	6	41	6	41	3.5
P27	=	80	110	82.02	36.8	M6	14	10	36.8	43	5.5	43	8	28	8	43	8	43	8	43	8	43	8	43	5.5

\* Per assemblare il motore è necessario smontare la flangia dal riduttore (vedere schema di montaggio 2 a pag. 21).

\* To mount the motor it is necessary to remove the gearbox flange (see assembly drawing 2 on page 21).

\* Vor dem Einbauen des Motors soll die Getriebeflansch abmontiert werden (siehe Bauanleitung 2 auf Seite 21).



# REP125 RIDUTTORI EPICICLOIDALI DI PRECISIONE

## 1.9 DATI TECNICI

## 1.9 TECHNICAL DATA

## 1.9 TECHNISCHE DATEN

Stadi Steps Stufenzahl	1				2								3							
i	3	4	5	7	9	12	16	20	28	35	49	36	48	64	80	100	140	196	245	343
$n_1$ nom	3000				3500								4000							
$n_1$ max	5000																			
$T_{2N}$	220	230	200	160	250	260	260	260	260	230	180	280	280	280	280	280	280	280	250	200
$T_{2A}$	350	370	320	300	400	420	420	420	420	370	350	450	450	450	450	450	450	450	400	370
$T_{2S}$	700	750	650	600	800	850	850	850	850	750	700	900	900	900	900	900	900	900	800	750
J	Vedi pag. 10 / See on page 10 / Siehe Seite 10																			
LpA	< 70																			
$R_d$	0.96				0.93								0.91							
$L_h$	20000																			
$F_{R2}$	3700																			
$F_{A2}$	1850																			
$R_t$	32																			
max	4'				6'								8'							
Kg	7.2				9.3								11.4							

**i** Rapporto di riduzione nominale  
 **$n_1$  nom** Velocità nominale in entrata [ $\text{min}^{-1}$ ]  
 **$n_1$  max** Velocità massima in entrata [ $\text{min}^{-1}$ ]  
 **$T_{2N}$**  Coppia nominale intermittente in uscita [Nm]  
 **$T_{2A}$**  Coppia massima di accelerazione in uscita [Nm]  
 **$T_{2S}$**  Coppia massima di emergenza in uscita [Nm]  
**LpA** Livello di rumorosità dB(A) a  $3000 \text{ min}^{-1}$   
 **$R_d$**  Rendimento dinamico  
 **$L_h$**  Durata cuscinetti [h]  
 **$F_{R2}$**  Carico radiale nominale in uscita [N] a  $300 \text{ min}^{-1}$   
 **$F_{A2}$**  Carico assiale in uscita [N] a  $300 \text{ min}^{-1}$   
 **$R_t$**  Rigidezza torsionale [Nm / arcmin]  
 **$J$  max** Gioco angolare massimo [arcmin]  
**J** Momento d'inerzia [ $\text{kg}\cdot\text{cm}^2$ ]

**Nominal ratio**  
**Nominal input speed [ $\text{min}^{-1}$ ]**  
**Maximum input speed [ $\text{min}^{-1}$ ]**  
**Rated intermittent output torque [Nm]**  
**Maximum acceleration output torque [Nm]**  
**Maximum emergency output torque [Nm]**  
**Noise level dB(A) at  $3000 \text{ min}^{-1}$**   
**Dynamic efficiency**  
**Bearing life [h]**  
**Rated output radial load [N] at  $300 \text{ min}^{-1}$**   
**Output axial load [N] at  $300 \text{ min}^{-1}$**   
**Torsional rigidity [Nm / arcmin]**  
**Maximum backlash [arcmin]**  
**Moment of inertia [ $\text{kg}\cdot\text{cm}^2$ ]**

**Nenn-Untersetzungsverhältnis**  
**Nenn-Eingangsdrehzahl [ $\text{min}^{-1}$ ]**  
**Maximale Eingangsdrehzahl [ $\text{min}^{-1}$ ]**  
**Maximale Beschleunigungsmoment am Abtrieb [Nm]**  
**Nenn-Abtriebsmoment (im Aussetzbetrieb)[Nm]**  
**Maximales Beschleunigungsmoment am Abtrieb [Nm]**  
**Maximale Überlast am Abtrieb [Nm]**  
**Geräuschpegel dB(A) bei  $3000 \text{ min}^{-1}$**   
**Dynamischer Wirkungsgrad**  
**Lebensdauer der Lager [h]**  
**Nenn-Radiallast an der Abtriebswelle bei  $300 \text{ min}^{-1}$**   
**Axiallast an der Abtriebswelle bei  $300 \text{ min}^{-1}$**   
**Drehfestigkeit [Nm / arcmin]**  
**Maximale Winkelspiel [arcmin]**  
**Traegheitsmoment [ $\text{kg}\cdot\text{cm}^2$ ]**

## 1.10 DIMENSIONI

## 1.10 DIMENSIONS

## 1.10 ABMESSUNGEN

Dimensioni generali e uscite / General and output dimensions / General-und Abtriebsabmessungen

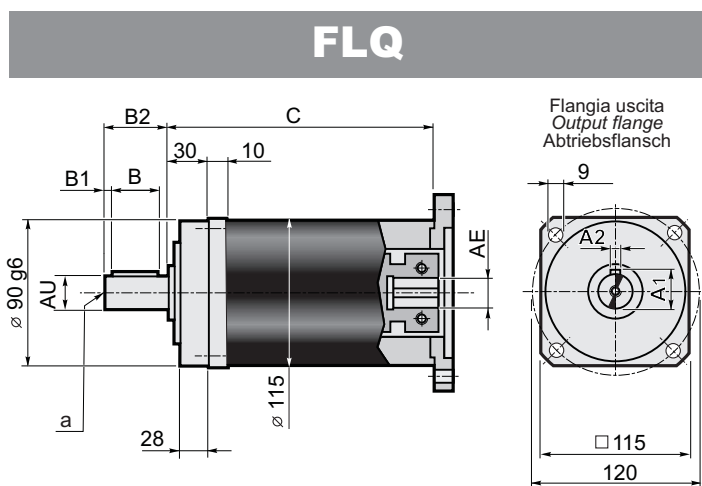
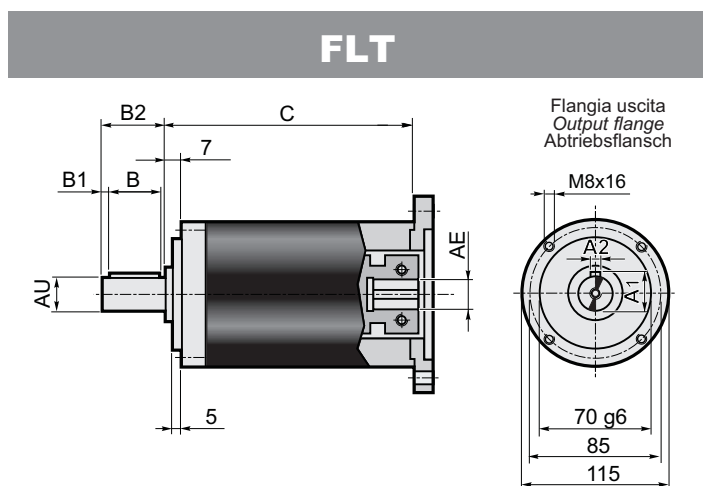

Stadi/Steps/Stufenzahl	1	2	3	
C	126	158.4	191	AE= 12.7-14-15.87-16-19
	145	177	210	AE= 22-24-28

	Albero uscita - Output shaft - Abtriebswelle						
	AU j6	A1	A2	B	B1	B2	a
AU25	25	28	8	40	5	50	M8x20
AU32	32	35	10	50	4	58	M10x25

# RIDOTTORI EPICICLOIDALI DI PRECISIONE **REP125**

Dimensioni entrate

Input dimensions

Antriebsabmessungen

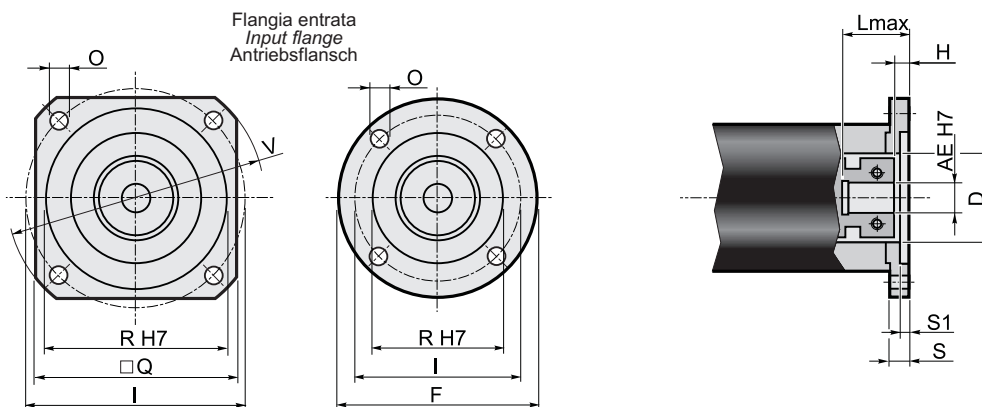

	Flange entrata / Input flange / Antriebsflansch									Albero entrata - Input shaft - Antriebswelle															
										AE															
	F	Q	V	I	R (H7)	O	S	S1	D	12.7	14	15.87	16	19	22	24	28								
P01*	=	115	140	125.72	55.52	6.5	13	3	55.52	L <sub>max</sub>	H	L <sub>max</sub>	H	L <sub>max</sub>	H	L <sub>max</sub>	H	L <sub>max</sub>	H	L <sub>max</sub>	H	L <sub>max</sub>	H		
P02*	115	=	=	75	60	5.5	13	3.5	60	43	6	35	6	43	6	43	6	43	6	62	6	62	6	62	6
P03*	115	=	=	85	70	6.5	13	3.5	60	43	6	35	6	43	6	43	6	43	6	62	6	62	6	62	6
P04*	115	=	=	98.42	73.02	6.5	13	3	60	43	6	35	6	43	6	43	6	43	6	62	6	62	6	62	6
P05*	120	=	=	100	80	6.5	13	4	60	43	6	35	6	43	6	43	6	43	6	62	6	62	6	62	6
P06*	=	115	140	115	95	9	13	4.5	60	43	6	35	6	43	6	43	6	43	6	62	6	62	6	62	6
P07	=	115	160	130	110	8.5	13	4.5	60	43	6	35	6	43	6	43	6	43	6	62	6	62	6	62	6
P08	=	142	190	165	130	11	13	4.5	60	43	6	35	6	43	6	43	6	43	6	62	6	62	6	62	6
P09	=	192	250	215	180	13	14	4.5	60	44	7	36	7	44	7	44	7	44	7	63	7	63	7	63	7
P10*	115	=	=	65	50	6.5	13	3.5	50	43	6	35	6	43	6	43	6	43	6	62	6	62	6	62	6
P11	=	130	170	145	110	M 8	31	7	60	61	24	53	24	61	24	61	24	61	24	80	24	80	24	80	24
P12	=	130	170	145	110	M 8	17	7	60	47	10	39	10	47	10	47	10	47	10	66	10	66	10	66	10
P13	=	115	160	130	110	M 8	13	4.5	60	43	6	35	6	43	6	43	6	43	6	62	6	62	6	62	6
P14*	115	=	=	70	50	6.5	13	3.5	50	43	6	35	6	43	6	43	6	43	6	62	6	62	6	62	6
P15	115	=	=	90	70	M5	11	3.5	60	41	4	33	4	41	4	41	4	41	4	60	4	60	4	60	4
P17*	115	=	=	90	70	6.5	13	3.5	60	43	6	35	6	43	6	43	6	43	6	62	6	62	6	62	6
P18	=	115	155	130	95	8.5	13	4.5	60	43	6	35	6	43	6	43	6	43	6	62	6	62	6	62	6
P19*	115	=	=	95	50	6.5	13	3.5	50	43	6	35	6	43	6	43	6	43	6	62	6	62	6	62	6
P20	115	=	=	99	60	M6	13	4	60	43	6	35	6	43	6	43	6	43	6	62	6	62	6	62	6

\* Per assemblare il motore è necessario smontare la flangia dal riduttore (vedere schema di montaggio 2 a pag. 21).

\* To mount the motor it is necessary to remove the gearbox flange (see assembly drawing 2 on page 21).

\* Vor dem Einbauen des Motors soll die Getriebeflangsch abmontiert werden (siehe Bauanleitung 2 auf Seite 21).

# REP150 RIDUTTORI EPICICLOIDALI DI PRECISIONE

## 1.9 DATI TECNICI

## 1.9 TECHNICAL DATA

## 1.9 TECHNISCHE DATEN

Stadi Steps Stufenzahl	1				2								3							
	3	4	5	7	9	12	16	20	28	35	49	36	48	64	80	100	140	196	245	343
<b>i</b>	3000				3500								4000							
<b>n<sub>1</sub> nom</b>	3000				3500								4000							
<b>n<sub>1</sub> max</b>	5000																			
<b>T<sub>2N</sub></b>	430	470	410	340	500	560	560	560	560	470	370	600	600	600	600	600	600	600	500	450
<b>T<sub>2A</sub></b>	700	750	650	600	800	900	900	900	900	750	700	950	950	950	950	950	950	950	800	750
<b>T<sub>2S</sub></b>	1400	1500	1300	1200	1600	1800	1800	1800	1800	1500	1400	1900	1900	1900	1900	1900	1900	1900	1600	1500
<b>J</b>	Vedi pag. 10 / See on page 10 / Siehe Seite 10																			
<b>LpA</b>	< 70																			
<b>R<sub>d</sub></b>	0.96				0.93								0.91							
<b>L<sub>h</sub></b>	20000																			
<b>F<sub>R2</sub></b>	6600																			
<b>F<sub>A2</sub></b>	3300																			
<b>R<sub>t</sub></b>	60																			
<b>max</b>	4'				6'								8'							
<b>Kg</b>	13.0				17.0								21							

<b>i</b>	Rapporto di riduzione nominale	<i>Nominal ratio</i>	Nenn-Untersetzungsverhältnis
<b>n<sub>1</sub> nom</b>	Velocità nominale in entrata [min <sup>-1</sup> ]	<i>Nominal input speed [min<sup>-1</sup>]</i>	Nenn-Eingangsdrehzahl [min <sup>-1</sup> ]
<b>n<sub>1</sub> max</b>	Velocità massima in entrata [min <sup>-1</sup> ]	<i>Maximum input speed [min<sup>-1</sup>]</i>	Maximale Eingangsdrehzahl [min <sup>-1</sup> ]
<b>T<sub>2N</sub></b>	Coppia nominale intermittente in uscita [Nm]	<i>Rated intermittent output torque [Nm]</i>	Nenn-Abtriebsmoment (im Aussetzbetrieb)[Nm]
<b>T<sub>2A</sub></b>	Coppia massima di accelerazione in uscita [Nm]	<i>Maximum acceleration output torque [Nm]</i>	Maximales Beschleunigungsmoment am Abtrieb [Nm]
<b>T<sub>2S</sub></b>	Coppia massima di emergenza in uscita [Nm]	<i>Maximum emergency output torque [Nm]</i>	Maximale Überlast am Abtrieb [Nm]
<b>LpA</b>	Livello di rumorosità dB(A) a 3000 min <sup>-1</sup>	<i>Noise level dB(A) at 3000 min<sup>-1</sup></i>	Geräuschpegel dB(A) bei 3000 min <sup>-1</sup>
<b>Rd</b>	Rendimento dinamico	<i>Dynamic efficiency</i>	Dynamischer Wirkungsgrad
<b>L<sub>h</sub></b>	Durata cuscinetti [h]	<i>Bearing life [h]</i>	Lebensdauer der Lager [h]
<b>F<sub>R2</sub></b>	Carico radiale nominale in uscita [N] a 300min <sup>-1</sup>	<i>Rated output radial load [N] at 300min<sup>-1</sup></i>	Nenn-Radiallast an der Abtriebswelle bei 300min <sup>-1</sup>
<b>F<sub>A2</sub></b>	Carico assiale in uscita [N] a 300min <sup>-1</sup>	<i>Output axial load [N] at 300min<sup>-1</sup></i>	Axiallast an der Abtriebswelle bei 300min <sup>-1</sup>
<b>R<sub>t</sub></b>	Rigidità torsionale [Nm / arcmin]	<i>Torsional rigidity [Nm / arcmin]</i>	Drehfestigkeit [Nm / arcmin]
<b>J</b>	Gioco angolare massimo [arcmin]	<i>Maximum backlash [arcmin]</i>	Maximale Winkelspiel [arcmin]
<b>J</b>	Momento d'inerzia [kg·cm <sup>2</sup> ]	<i>Moment of inertia [kg·cm<sup>2</sup>]</i>	Traegheitsmoment [kg·cm <sup>2</sup> ]

## 1.10 DIMENSIONI

## 1.10 DIMENSIONS

## 1.10 ABMESSUNGEN

Dimensioni generali e uscite / *General and output dimensions* / General-und Abtriebsabmessungen

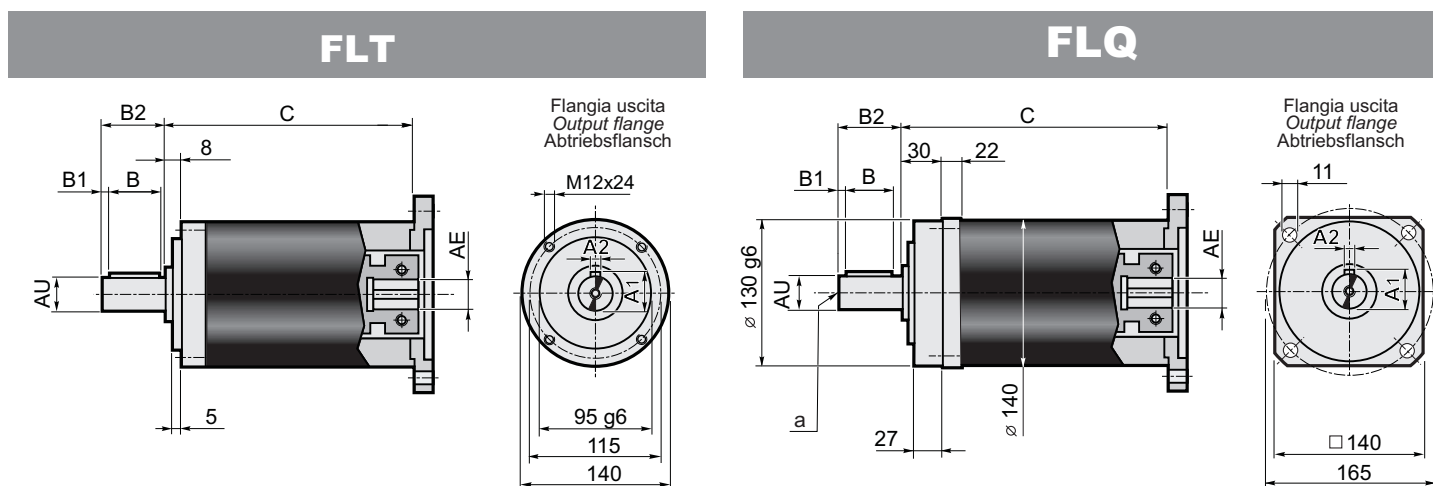

Stadi/Steps/Stufenzahl	1	2	3	
<b>C</b>	160	201	242	AE= 15.87-16-19-22-24
	185	226	267	AE= 28-32-35-38

	Albero uscita - <i>Output shaft</i> - Abtriebswelle						
	AU j6	A1	A2	B	B1	B2	a
<b>AU38</b>	38	41	10	70	5	80	M10x25
<b>AU40</b>	40	43	12	70	5	80	M10x25

# RIDUTTORI EPICICLOIDALI DI PRECISIONE **REP150**

Dimensioni entrate

Input dimensions

Antriebsabmessungen

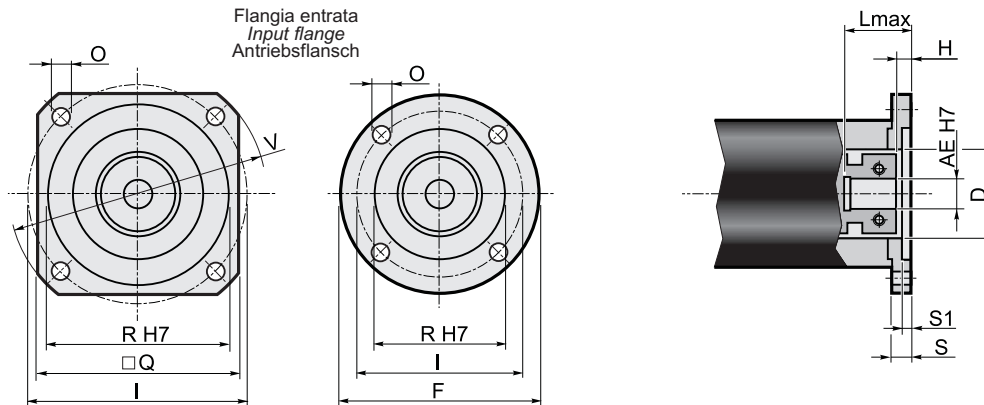

Flange entrata / Input flange / Antriebsflansch	Albero entrata - Input shaft - Antriebswelle																																
										AE																							
	F	Q	V	I	R (H7)	O	S	S1	D	15.87	16	19	22	24	28	32	35	38	L max	H	L max	H	L max	H	L max	H	L max	H	L max	H	L max	H	L max
P01*	140	=	=	125.72	55.52	6.5	15	4	55.52	57.8	6.8	57.8	6.8	42.8	6.8	57.8	6.8	57.8	6.8	82.8	7.3	82.8	7.3	82.8	7.3	82.8	7.3	82.8	7.3	82.8	7.3	82.8	7.3
P02*	140	=	=	100	80	6.5	15	4	70	57.8	6.8	57.8	6.8	42.8	6.8	57.8	6.8	57.8	6.8	82.8	7.3	82.8	7.3	82.8	7.3	82.8	7.3	82.8	7.3	82.8	7.3	82.8	7.3
P03*	140	=	=	115	95	8.5	15	4.5	70	57.8	6.8	57.8	6.8	42.8	6.8	57.8	6.8	57.8	6.8	82.8	7.3	82.8	7.3	82.8	7.3	82.8	7.3	82.8	7.3	82.8	7.3	82.8	7.3
P04*	=	140	160	130	110	8.5	15	4.5	70	57.8	6.8	57.8	6.8	42.8	6.8	57.8	6.8	57.8	6.8	82.8	7.3	82.8	7.3	82.8	7.3	82.8	7.3	82.8	7.3	82.8	7.3	82.8	7.3
P05	=	142	190	165	130	11	15	4.5	70	57.8	6.8	57.8	6.8	42.8	6.8	57.8	6.8	57.8	6.8	82.8	7.3	82.8	7.3	82.8	7.3	82.8	7.3	82.8	7.3	82.8	7.3	82.8	7.3
P06	=	190	250	215	180	13	15	4.5	70	57.8	6.8	57.8	6.8	42.8	6.8	57.8	6.8	57.8	6.8	82.8	7.3	82.8	7.3	82.8	7.3	82.8	7.3	82.8	7.3	82.8	7.3	82.8	7.3
P07	=	250	300	265	230	13	15	4.5	70	57.8	6.8	57.8	6.8	42.8	6.8	57.8	6.8	57.8	6.8	82.8	7.3	82.8	7.3	82.8	7.3	82.8	7.3	82.8	7.3	82.8	7.3	82.8	7.3
P08	=	130	165	145	110	M 8	18	7	70	60.8	9.8	60.8	9.8	45.8	9.8	60.8	9.8	60.8	9.8	85.8	10.3	85.8	10.3	85.8	10.3	85.8	10.3	85.8	10.3	85.8	10.3	85.8	10.3
P09	=	180	230	200	114.3	13.5	22	11	70	64.8	13.8	64.8	13.8	49.8	13.8	64.8	13.8	64.8	13.8	89.8	14.3	89.8	14.3	89.8	14.3	89.8	14.3	89.8	14.3	89.8	14.3	89.8	14.3
P10	=	115	150	130	95	M 8	15	4.5	70	57.8	6.8	57.8	6.8	42.8	6.8	57.8	6.8	57.8	6.8	82.8	7.3	82.8	7.3	82.8	7.3	82.8	7.3	82.8	7.3	82.8	7.3	82.8	7.3
P11	=	180	230	198	155	13.5	22	7	120x11	64.8	13.8	64.8	13.8	49.8	13.8	64.8	13.8	64.8	13.8	89.8	14.3	89.8	14.3	89.8	14.3	89.8	14.3	89.8	14.3	89.8	14.3	89.8	14.3
P12	=	220	270	235	200	13.5	15	5	70	57.8	6.8	57.8	6.8	42.8	6.8	57.8	6.8	57.8	6.8	82.8	7.3	82.8	7.3	82.8	7.3	82.8	7.3	82.8	7.3	82.8	7.3	82.8	7.3
P13	=	190	250	215	130	13	15	4.5	70	57.8	6.8	57.8	6.8	42.8	6.8	57.8	6.8	57.8	6.8	82.8	7.3	82.8	7.3	82.8	7.3	82.8	7.3	82.8	7.3	82.8	7.3	82.8	7.3
P14	=	142	190	165	110	11	15	4.5	70	57.8	6.8	57.8	6.8	42.8	6.8	57.8	6.8	57.8	6.8	82.8	7.3	82.8	7.3	82.8	7.3	82.8	7.3	82.8	7.3	82.8	7.3	82.8	7.3
P15*	150	=	=	90	70	6.5	15	4	70	57.8	6.8	57.8	6.8	42.8	6.8	57.8	6.8	57.8	6.8	82.8	7.3	82.8	7.3	82.8	7.3	82.8	7.3	82.8	7.3	82.8	7.3	82.8	7.3

\* Per assemblare il motore è necessario smontare la flangia dal riduttore (vedere schema di montaggio 2 a pag. 21).

\* To mount the motor it is necessary to remove the gearbox flange (see assembly drawing 2 on page 21).

\* Vor dem Einbauen des Motors soll die Getriebeflangsch abmontiert werden (siehe Bauanleitung 2 auf Seite 21).

## RIDUTTORI EPICICLOIDALI DI PRECISIONE

### 1.11 Istruzioni per il montaggio del motore

### 1.11 Instructions for assembly of motor

### 1.11 Anleitung für Motormontage

1

Schema di montaggio / Assembly drawing / Bauanleitung 1

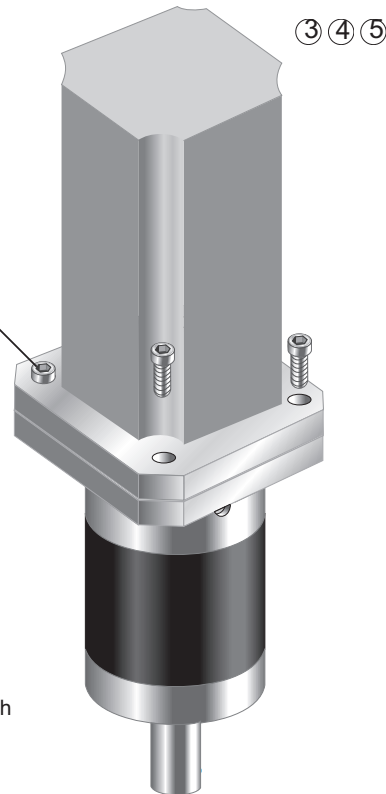
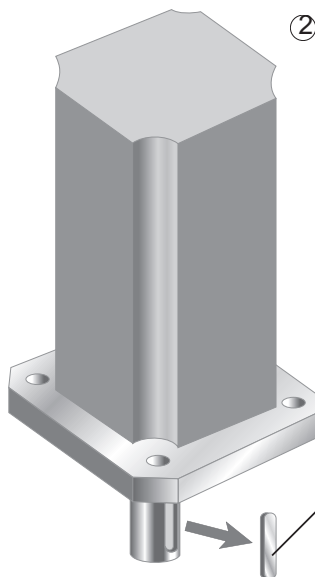
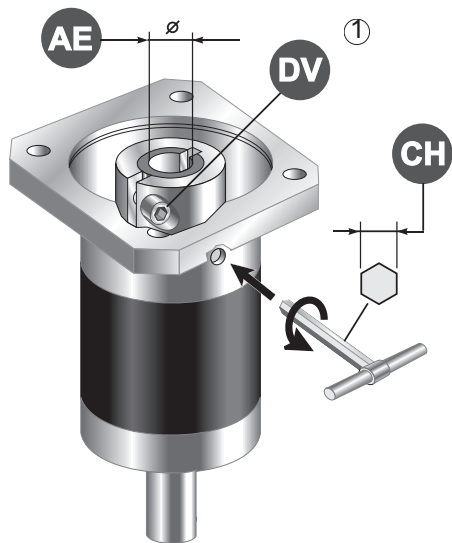

- 1 - Allentare la vite di serraggio del morsetto (DV)
- 2 - Estrarre la linguetta (LM) dall'albero motore
- 3 - Pulire le superfici di contatto delle flange motore e riduttore
- 4 - Calettare il motore sul riduttore evitando urti
- 5 - Stringere le viti di assemblaggio (FV) in modo alternato
- 6 - Serrare lavite (o le viti) del morsetto (DV) alla coppia (CS) indicata in tabella

- 1 - Unloose the fastening screw (or screws) of the clamp (DV)
- 2 - Remove the key (LM) from motor shaft
- 3 - Clean the contact surfaces of motor flange/gearbox flange
- 4 - Avoid impacts while fitting motor to gearbox
- 5 - Tighten the assembling screws (FV) alternatively
- 6 - Tighten the clamp screw, or screws (DV) according to the torque (CS) reported in the table

- 1 - die Befestigungsschraube der Klammer (DV) lockern
- 2 - die Feder (LM) aus Motorwelle ziehen
- 3 - die Motorflansch / Getriebeflansch Kontaktfläche reinigen
- 4 - Motor und Getriebe ohne Stöße verkeilen
- 5 - die Befestigungsschrauben (FV) abwechselnd anziehen
- 6 - die Schraube (oder Schrauben) der Klammer (DV) zu dem in der Tabelle angegebenen Anzugsmoment anziehen

REP 075	AE	6	6.35	7	8	9	9.52	11	12	12.7	14	
	DV	M4										
	NV	1										
	CH	3										
	CS [Nm]	4.8										
REP 100	AE	9	9.52	11	12	12.7	14	15.87	16	19		
	DV	M4						M5				
	NV	1						1				
	CH	3						4				
	CS [Nm]	4.8						9.4				
REP 125	AE	12.7	14	15.87	16	19	22	24	28			
	DV	M4			M5			M6				
	NV	1			1			2				
	CH	3			4			5				
	CS [Nm]	4.8			9.4			16.2				
REP 150	AE	15.87	16	19	22	24	28	32	35	38		
	DV	M6			M6			M6				
	NV	1			2			3				
	CH	5			5			5				
	CS [Nm]	16.2			16.2			16.2				

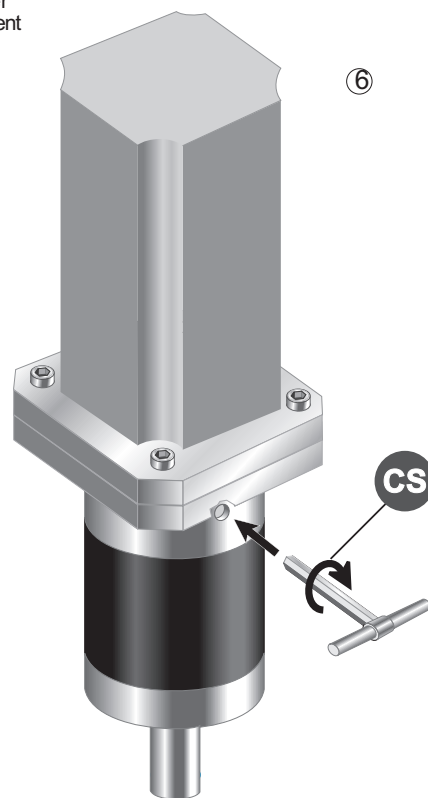

AE= Albero entrata / Input shaft / Antriebswelle  
 DV= Diametro vite / Screw diameter / Schraubendurchmesser

NV= Numero viti / Number of screw / Schraubenanzahl  
 CS= Coppia di serraggio / Setting torque / Spannungsmoment

## RIDUTTORI EPICICLOIDALI DI PRECISIONE

### 1.11 Istruzioni per il montaggio del motore

### 1.11 Instructions for assembly of motor

### 1.11 Anleitung für Motormontage

2

Schema di montaggio / Assembly drawing / Bauanleitung 2

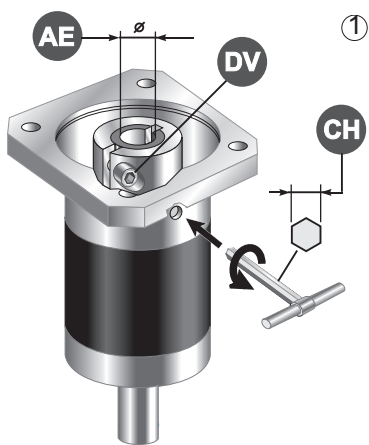

1

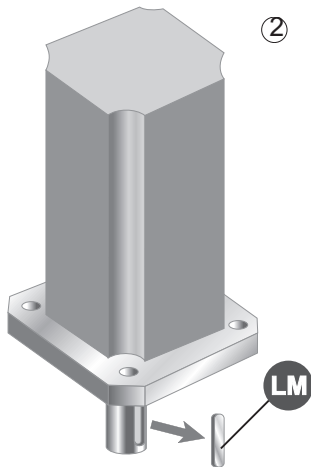

2

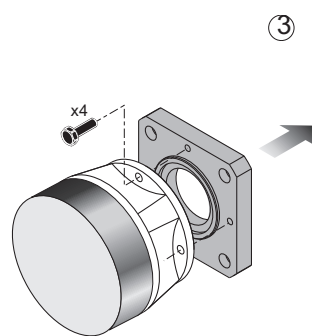

3

- 1 - Allentare la vite di serraggio del morsetto (DV)
- 2 - Estrarre la linguetta (LM) dall'albero motore
- 3 - Smontare la flangia dal riduttore
- 4 - Pulire le superfici di contatto delle flange motore e riduttore
- 5 - Fissare la flangia sul motore
- 6 - Calettare il motore sul riduttore evitando urti
- 7 - Stringere le viti di assemblaggio (FV) in modo alternato
- 8 - Serrare la vite (o le viti) del morsetto (DV) alla coppia (CS) indicata in tabella

- 1 - Unloose the fastening screw (or screws) of the clamp (DV)
- 2 - Remove the key (LM) from motor shaft
- 3 - Remove the flange from the gearbox
- 4 - Clean the contact surfaces of motor flange/gearbox flange
- 5 - Fix the flange on the motor
- 6 - Avoid impacts while fitting motor to gearbox
- 7 - Tighten the assembling screws (FV) alternatively
- 8 - Tighten the clamp screw, or screws (DV) according to the torque (CS) reported in the table

- 1 - die Befestigungsschraube der Klammer (DV) lockern
- 2 - die Feder (LM) aus Motorwelle ziehen
- 3 - die Flansch von Getriebe abmontieren
- 4 - die Motorflansch / Getriebe-flansch Kontaktfläche reinigen
- 5 - die Flansch an Motor befestigen
- 6 - Motor und Getriebe ohne Stöße verkeilen
- 7 - die Befestigungsschrauben (FV) abwechselnd anziehen
- 8 - die Schraube (oder Schrauben) der Klammer (DV) zu dem in der Tabelle angegebenen Anzugsmoment anziehen

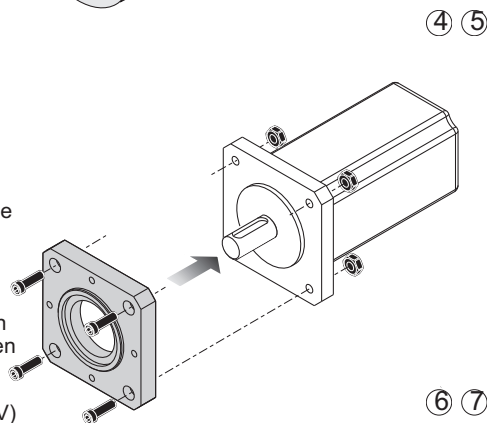

4 5

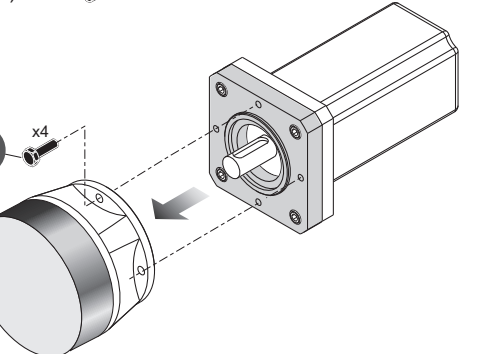

6 7

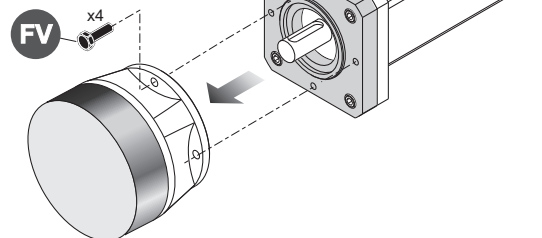

8

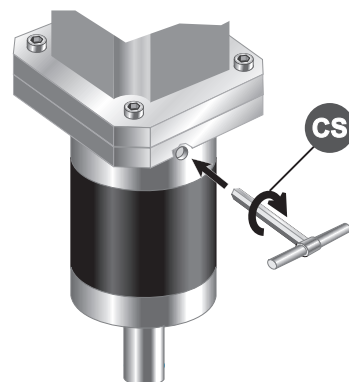

REP 075	AE	6	6.35	7	8	9	9.52	11	12	12.7	14	
	DV	M4										
	NV	1										
	CH	3										
	CS [Nm]	4.8										
REP 100	AE	9	9.52	11	12	12.7	14	15.87	16	19		
	DV	M4						M5				
	NV	1						1				
	CH	3						4				
	CS [Nm]	4.8						9.4				
REP 125	AE	12.7	14	15.87	16	19	22	24	28			
	DV	M4			M5			M6				
	NV	1			1			2				
	CH	3			4			5				
	CS [Nm]	4.8			9.4			16.2				
REP 150	AE	15.87	16	19	22	24	28	32	35	38		
	DV	M6			M6				M6			
	NV	1			2				3			
	CH	5			5				5			
	CS [Nm]	16.2			16.2				16.2			

AE= Albero entrata / Input shaft / Antriebswelle  
 DV= Diametro vite / Screw diameter / Schraubendurchmesser

NV= Numero viti / Number of screw / Schraubenanzahl  
 CS= Coppia di serraggio / Setting torque / Spannungsmoment

## RIDUTTORI EPICICLOIDALI DI PRECISIONE

### 1.12 ESEMPI DI APPLICAZIONI

### 1.12 EXAMPLES OF APPLICATIONS

### 1.12 ANWENDUNGSBEISPIELE

#### CARRELLO SCORREVOLE

#### SLIDING CARRIAGE

#### LAUFWAGEN

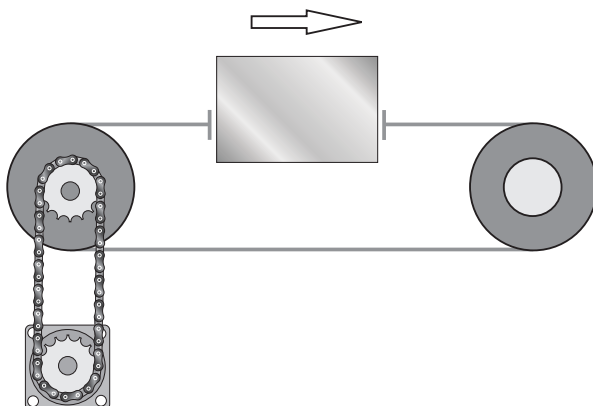

L'applicazione prevede la movimentazione lineare di una tavola tramite una catena (rapporto di riduzione della trasmissione:  $i=1$ )  
 La massa del carrello è di  $m=200$  kg.  
 Il pignone, montato sull'albero uscita del riduttore, ha diametro primitivo  $D_p=0.1$ m.  
 Il carrello deve essere accelerato in  $t_a=0.2$  s ad una velocità massima  $v_2=0.6$  m/s.  
 Il rapporto di riduzione del riduttore è  $i=20$ .  
 La forza resistente che si oppone allo spostamento è pari a  $F=500$ N (data dal prodotto della forza per il coefficiente di attrito).

The application requires the linear motion of a table (see picture) by means of a chain (reduction ratio of the transmission:  $i=1$ ).  
 The carriage mass is  $m=200$  Kg.  
 The pinion, which is mounted on the gearbox output shaft, features a pitch diameter  $\varnothing p=0.1$ m.  
 The carriage has to be accelerated in  $t_a=0.2$  s to a maximum speed  $v_2=0.6$ m/s.  
 The reduction ratio of the gearbox is  $i=20$ .  
 The resisting force acting against the motion is  $F=500$ N (product of the force by the coefficient of friction).

Die Applikation sieht die Linearbewegung einer Scheibe durch eine Kette vor. (Übersetzungsverhältnis:  $i=1$ )  
 Die Masse der Wagen ist  $m=200$  Kg.  
 Der auf der Getriebeabtriebswelle montierten Ritzel weist einen Durchmesser  $\varnothing p=0.1$ m.  
 Der Wagen soll in  $t_a=0.2$  s bis Höchstgeschwindigkeit  $v_2=0.6$  m/s beschleunigt werden.  
 Das Übersetzungsverhältnis des Getriebes ist  $i=20$ .  
 Die Widerstandskraft, die gegen die Bewegung wirkt, ist  $F=500$ N (Produkt von Kraft mal Reibungskoeffizient)

- Determinazione della coppia resistente  $T_{RES}$

$$T_{RES} = F \cdot r = 500 \cdot 0.1 / 2 = 25 \text{ Nm}$$

- Determinazione della coppia resistente  $T_{IN}$  dovuta all'inerzia

$$T_{IN} = F_i \cdot D_p / 2 \text{ (Nm)}$$

Dove  $F_i$  è la forza di inerzia, la quale, nel caso di traslazione, vale:

$$F_i = m \cdot a \quad (\text{N})$$

In questo caso, l'accelerazione risulta:

$$a = (v_2 - v_0) / t_a \quad (\text{m/s}^2)$$

con  $v_2$  = velocità finale (m/s)  
 $v_0$  = velocità iniziale (m/s)  
 $t_a$  = tempo di accelerazione (s)

quindi:

$$a = (0.6 - 0) / 0.2 = 3 \text{ m/s}^2$$

$$F_i = 200 \cdot 3 = 600 \text{ N}$$

$$T_{IN} = 600 \cdot 0.1 / 2 = 30 \text{ Nm}$$

Pertanto, la coppia da prendere in considerazione, per dimensionare correttamente l'applicazione, vale:

$$T_2 = T_{RES} + T_{IN} = 25 + 30 = 55 \text{ Nm}$$

In funzione di questo risultato si dovrà individuare un adeguato motore (in prima approssimazione:  $T_{MOT} = (T_2 / i) \cdot R_d$ ), tale cioè da garantire una coppia motrice sufficiente a vincere gli attriti e le inerzie presenti. Successivamente, in funzione delle caratteristiche del motore scelto e delle rimanenti specifiche dell'applicazione (ciclo di lavoro, numero di cicli all'ora ecc.) si procede selezionando opportunamente il riduttore (v. selezione del riduttore).

- Calculation of resisting torque  $T_{RES}$

$$T_{RES} = F \cdot r = 500 \cdot 0.1 / 2 = 25 \text{ Nm}$$

- Calculation of resisting torque of inertia  $T_{IN}$

$$T_{IN} = F_i \cdot D_p / 2 \text{ (Nm)}$$

$F_i$  is the inertial force which, in case of translation, is:

$$F_i = m \cdot a \quad (\text{N})$$

In this case, acceleration is:

$$a = (v_2 - v_0) / t_a \quad (\text{m/s}^2)$$

$v_2$  = final speed  
 $v_0$  = initial speed  
 $t_a$  = acceleration time (s)

Therefore:

$$a = (0.6 - 0) / 0.2 = 3 \text{ m/s}^2$$

$$F_i = 200 \cdot 3 = 600 \text{ N}$$

$$T_{IN} = 600 \cdot 0.1 / 2 = 30 \text{ Nm}$$

As a result, for the purpose of a correct dimensioning of the application, the following torque has to be taken into consideration:

$$T_2 = T_{RES} + T_{IN} = 25 + 30 = 55 \text{ Nm}$$

This value has to be taken into account when selecting the motor (approx.  $T_{MOT} = (T_2 / i) \cdot R_d$ ). The motor torque should be high enough as to overcome friction and inertia forces. Subsequently, it is possible to proceed with the selection of the gearbox on the basis of motor specifications and features of application (operation cycle, no. cycles per hour, etc.) (see Selection of the gearbox).

- Berechnung von Widerstandsdrehmoment  $T_{RES}$

$$T_{RES} = F \cdot r = 500 \cdot 0.1 / 2 = 25 \text{ Nm}$$

- Berechnung von Trägheitsdrehmoment  $T_{IN}$

$$T_{IN} = F_i \cdot D_p / 2 \text{ (Nm)}$$

$F_i$  ist die Trägheit, die im Falle von Translation wie folgt ist:

$$F_i = m \cdot a \quad (\text{N})$$

In diesem Fall ist die Beschleunigung wie folgt:

$$a = (v_2 - v_0) / t_a \quad (\text{m/s}^2)$$

Mit  $v_2$  = Endgeschwindigkeit  
 $v_0$  = Startgeschwindigkeit  
 $t_a$  = Beschleunigungszeit(s)

Folglich:

$$a = (0.6 - 0) / 0.2 = 3 \text{ m/s}^2$$

$$F_i = 200 \cdot 3 = 600 \text{ N}$$

$$T_{IN} = 600 \cdot 0.1 / 2 = 30 \text{ Nm}$$

Damit die Dimensionierung der Applikation korrekt ist, ist das folgendes Drehmoment zu betrachten:

$$T_2 = T_{RES} + T_{IN} = 25 + 30 = 55 \text{ Nm}$$

Von diesem Wert hängt die Wahl des Motors (annähernd:  $T_{MOT} = (T_2 / i) \cdot R_d$ ) ab. Das Antriebsdrehmoment muss ausreichend hoch sein, um Reibungs- und Trägheitskräfte überwinden zu können. Schließlich wird das Getriebe abhängig von Applikation (Arbeitszyklus, Zyklen pro Stunde, u.s.w.) und Motoreigenschaften gewählt. (Siehe Wahl des Getriebes).

## RIDUTTORI EPICICLOIDALI DI PRECISIONE

TAVOLA ROTANTE

REVOLVING TABLE

DREHSCHLEIBE

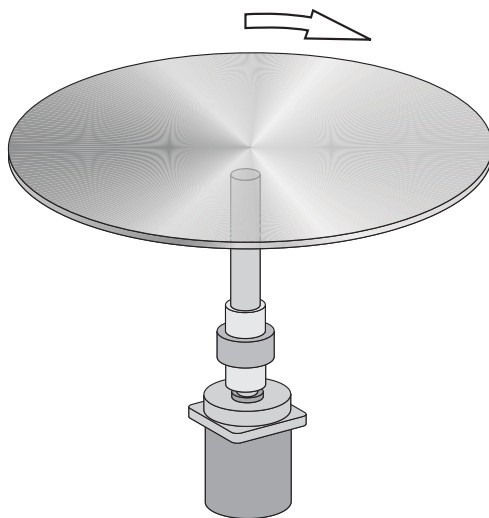

L'applicazione prevede la messa in rotazione di una tavola cilindrica di massa pari a  $m=20\text{kg}$  e raggio  $r=0.5\text{m}$ .

Tale tavola deve essere accelerata da  $n_0 = 0 \text{ min}^{-1}$  a  $n_1 = 300 \text{ rpm}$  in  $t_a=0.3 \text{ s}$ .

Il rapporto di riduzione del riduttore è  $i=20$ .

Si suppone che la coppia resistente per mantenere in rotazione uniforme la tavola sia trascurabile rispetto alla coppia legata all'inerzia dell'applicazione.

Quindi, in questo caso:

$$T_2 = T_{IN} = J \cdot a_a \quad (\text{Nm})$$

Dove  $J$  ( $\text{kgm}^2$ ) è il momento d'inerzia di massa della tavola rotante, ed  $a_a$  ( $\text{rad/s}^2$ ) è la accelerazione angolare.

$$J = (m \cdot r^2) / 2 = (20 \cdot 0.5^2) / 2 = 2.5 \text{ kgm}^2$$

$$a_a = \frac{1}{t_a} \cdot \Delta \omega \quad (\text{rad/s}^2)$$

$$1 = (2 \cdot n_1) / 60 = (2 \cdot 300) / 60 = 31.4 \text{ rad/s}$$

Quindi:

$$a_a = \frac{31.4}{0.3} = 104.6 \quad (\text{rad/s}^2)$$

Infine:

$$T_2 = T_{IN} = 2.5 \cdot 104.6 = 261 \text{ Nm}$$

In funzione di questo risultato si dovrà individuare un adeguato motore (in prima approssimazione:  $T_{MOT} = (T_2 / i) \cdot R_d$ ), tale cioè da garantire una coppia motrice sufficiente a vincere gli attriti e le inerzie presenti. Successivamente, in funzione delle caratteristiche del motore scelto e delle rimanenti specifiche dell'applicazione (ciclo di lavoro, numero di cicli all'ora ecc.) si procede selezionando opportunamente il riduttore (v. selezione del riduttore).

The application requires the rotation of a cylindrical table with mass  $m=20 \text{ Kg}$  and radius  $r=0.5\text{m}$ .

The table has to be accelerated from  $n_0=0 \text{ rpm}$  to  $n_1=300 \text{ min}^{-1}$  in  $t_a=0.3\text{s}$ .

The reduction ratio of the gearbox is  $i=20$ .

The resisting torque, which enables uniform rotation of the table, is assumed to be negligible compared to the torque caused by the inertia of the application.

Therefore, in this case:

$$T_2 = T_{IN} = J \cdot a_a \quad (\text{Nm})$$

$J$  ( $\text{kgm}^2$ ) is the moment of inertia of the mass of the revolving table and  $a_a$  ( $\text{rad/s}^2$ ) is the angular acceleration.

$$J = (m \cdot r^2) / 2 = (20 \cdot 0.5^2) / 2 = 2.5 \text{ kgm}^2$$

$$a_a = \frac{1}{t_a} \cdot \Delta \omega \quad (\text{rad/s}^2)$$

$$1 = (2 \cdot n_1) / 60 = (2 \cdot 300) / 60 = 31.4 \text{ rad/s}$$

Therefore:

$$a_a = \frac{31.4}{0.3} = 104.6 \quad (\text{rad/s}^2)$$

In conclusion:

$$T_2 = T_{IN} = 2.5 \cdot 104.6 = 261 \text{ Nm}$$

This value has to be taken into account when selecting the motor (approx.  $T_{MOT} = (T_2 / i) \cdot R_d$ ). The driving torque should be high enough as to overcome friction and inertia forces. Subsequently, proceed with the selection of the gearbox on the basis of motor specifications and features of application (operation cycle, no. cycles per hours, etc.) (see Selection of the gearbox).

Die Applikation sieht die Drehung einer zylindrischen Scheibe vor, deren Masse  $m=20\text{Kg}$  ist und deren Halbmesser  $r=0.5 \text{ s}$  ist.

Solche Scheibe soll von  $n_0 = 0 \text{ U/Min}$  bis  $n_1=300 \text{ min}^{-1}$  in  $t_a=0.3\text{s}$  beschleunigt werden.

Das Übersetzungsverhältnis des Getriebes ist  $i=20$ .

Es wird angenommen, dass das zur gleichmäßigen Drehung der Scheibe dienenden Widerstandsdrehmoment unbedeutend im Vergleich zum Trägheitsmoment ist.

Folglich, im diesem Fall:

$$T_2 = T_{IN} = J \cdot a_a \quad (\text{Nm})$$

$J$  ( $\text{kgm}^2$ ) ist das Trägheitsmoment der Masse der Drehscheibe und  $a_a$  ( $\text{rad/s}^2$ ) ist die Winkelbeschleunigung.

$$J = (m \cdot r^2) / 2 = (20 \cdot 0.5^2) / 2 = 2.5 \text{ kgm}^2$$

$$a_a = \frac{1}{t_a} \cdot \Delta \omega \quad (\text{rad/s}^2)$$

$$1 = (2 \cdot n_1) / 60 = (2 \cdot 300) / 60 = 31.4 \text{ rad/s}$$

Folglich:

$$a_a = \frac{31.4}{0.3} = 104.6 \quad (\text{rad/s}^2)$$

Schließlich:

$$T_2 = T_{IN} = 2.5 \cdot 104.6 = 261 \text{ Nm}$$

Von diesem Wert hängt die Wahl des Motors (annähernd:  $T_{MOT} = (T_2 / i) \cdot R_d$ ) ab. Das Antriebsdrehmoment muss ausreichend hoch sein, um Reibungs- und Trägheitskräfte überwinden zu können. Schließlich wird das Getriebe abhängig von Applikation (Arbeitszyklus, Zyklen pro Stunde, u.s.w.) und Motoreigenschaften gewählt (siehe Wahl des Getriebes).



## RIDUTTORI EPICICLOIDALI DI PRECISIONE

### 1.13 FORMULARIO

### 1.13 FORMULARY

### 1.13 FORMELSAMMLUNG

Calcolo dell'inerzia J / Calculation of inertia J / Berechnung der Tragheit J

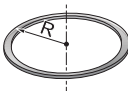
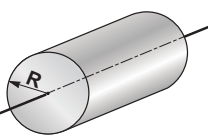
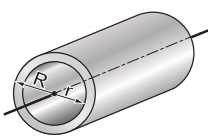
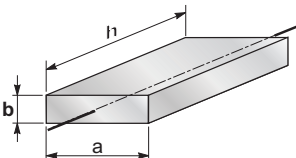
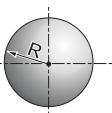
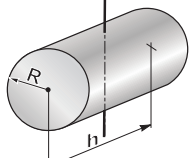
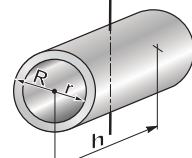
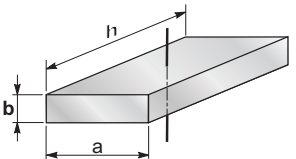
 $J = MR^2$	 $J = \frac{1}{2}MR^2$	 $J = \frac{M}{2}(R^2 + r^2)$	 $J = \frac{M}{12}(a^2 + b^2)$
 $J = \frac{2}{5}MR^2$	 $J = \frac{M}{4}R^2 + \frac{M}{3}h^2$	 $J = \frac{M}{4}(R^2 + r^2) + \frac{M}{3}h^2$	 $J = \frac{M}{12}h^2 + \frac{M}{12}a^2$

M	[Kg]	Massa	Weight	Maße
a, b, h	[m]	Dimensioni	Dimensions	Abmessungen
J	[Kgm <sup>2</sup> ]	Inerzia	Inertia	Traagheitsmoment

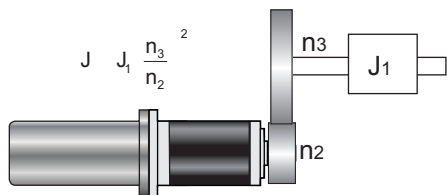

J = inerzia riferita all'albero uscita del riduttore con velocità  $n_2$  [rad/s] derivante da una massa con inerzia  $J_1$  e ruotante a velocità  $n_3$  [rad/s].

J = inertia referred to the gearbox output shaft with speed  $n_2$  [rad/s] resulting from a mass with inertia  $J_1$  rotating at  $n_3$  speed [rad/s].

J = Trägheit mit Bezug auf Getriebeabtriebswelle mit Drehzahl  $n_2$  [rad/s], die von einer Masse mit Trägheit  $J_1$  zu  $n_3$  Drehzahl ableitet [rad/s].

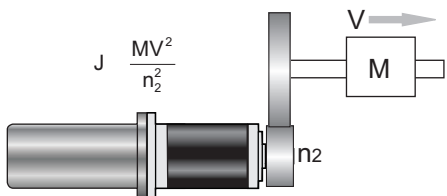

J = inerzia riferita all'albero uscita del riduttore con velocità  $n_2$  [rad/s] derivante da una massa traslante M [Kg] a velocità V [m/s].

J = inertia referred to the gearbox output shaft with speed  $n_2$  [rad/s] resulting from a translating mass M [Kg] at V speed [m/s].

J = Trägheit mit Bezug auf Getriebeabtriebswelle mit Drehzahl  $n_2$  [rad/s], die von einer Translation-Masse M [Kg] zu V Drehzahl [m/s] ableitet.

Relazioni fondamentali fra coppia T [Nm], inerzia J [Kgm<sup>2</sup>] e accelerazione angolare  $a_a$  [rad/s<sup>2</sup>].

Fundamental relations between torque T [Nm], inertia J [Kgm<sup>2</sup>] and angular acceleration  $a_a$  [rad/s<sup>2</sup>].

Wesentliche Relationen zwischen Drehmoment T [Nm], Trägheit J [Kgm<sup>2</sup>] und Winkelbeschleunigung  $a_a$  [rad/s<sup>2</sup>].

$$T = J a_a$$

Relazioni fondamentali fra coppia e potenza in entrata (T1, P1) e in uscita (T2, P2), il rendimento Rd e il rapporto di riduzione i del riduttore.

Fundamental relations between input torque and power (T1, P1), output torque and power (T2, P2), efficiency Rd, gearbox reduction ratio i.

Wesentliche Relationen zwischen Antriebsdrehmoment und -leistung (T1, P1), Abtriebsdrehmoment und -leistung (T2, P2), Wirkungsgrad Rd, Untersetzungsverhältnis i des Getriebes.

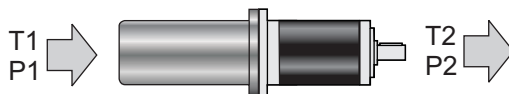

$$P_2 = P_1 R_d \quad T_2 = T_1 i R_d$$